

**Calgary**



# **Design Guidelines**

## **For City of Calgary Funded Buildings**

**Volume 1**  
**Technical Guide**  
**Version 2.0**

# Authentication and Validation

Civil, Structural and Building Envelope

Sustainability

Mechanical

Electrical

Architectural

Permit to Practice



Prepared by:

The City of Calgary  
DCMO  
Corporate Analytics and Innovation  
Corporate Engineering and Energy

Reviewed by, with appreciation:

David Bateman, (formerly) Facility Management  
Danny Byrgesen, Facility Management  
Patrick Giroux, Information Technology  
Mohammadreza Joodaki, Calgary Fire Department  
Ian Lofthouse, Information Technology  
Madyson McKay, Calgary Housing  
Alan Reynolds, Waste & Recycling Services  
Ben Selirio, Waste & Recycling Services  
Keir Stuhlmiller, Facility Management  
Monica Tran, Facility Management  
Alice Yu, Environmental and Safety Management





## Table of contents

<b>Section 1 – Introduction</b> .....	<b>1</b>
<b>Section 2 – Sustainability</b> .....	<b>5</b>
<b>Section 3 – Architectural</b> .....	<b>9</b>
<b>Section 4 – Civil</b> .....	<b>14</b>
<b>Section 5 – Building Envelope</b> .....	<b>16</b>
<b>Section 6 – Structural</b> .....	<b>22</b>
<b>Section 7 – Mechanical</b> .....	<b>35</b>
<b>Section 8 – Electrical</b> .....	<b>54</b>
<b>Section 9 – Acoustics and Vibration</b> .....	<b>70</b>
<b>Section 10 – Environmental/Hazardous Materials</b> .....	<b>74</b>





# Section 1 – Introduction

- 1.1 Intent..... 2
- 1.2 Guidelines Limitations..... 2
- 1.3 Other City of Calgary and Civic Partner Design Requirements ..... 3
- 1.4 Codes, Standards, and Guidelines – General..... 4

## 1.1 Intent

- .1 To apply to design of all new vertical infrastructure (e.g., buildings, relocatable structures such as modular structures, fabric structures, other facilities, and their associated sites) and to design of additions, upgrades, and renovations to existing vertical infrastructure.
- .2 To aid consultants in developing technical designs for City of Calgary and funded civic partner vertical infrastructure. Project Managers of Corporate business units and civic partners should direct consultants to utilize this document in their design.
- .3 To avoid unnecessary re-design time and effort, and avoidable changes during design, construction or post-occupancy.
- .4 To be followed with reasoned judgement when considering applicability to specific and nontypical situations.
- .5 To set minimum requirements on components, systems, and equipment that affect serviceability, durability, sustainability, and anticipated life expectancy of a facility.
- .6 To maximize functionality and efficient operation to minimize capital and operating expense and premature obsolescence of facilities.
- .7 To restrict the use of equipment and systems that have historically been problematic for City facilities.
- .8 Not to limit the development or application of creative or innovative design solutions. When such alternative design solutions or systems are being considered, the consultant will submit a written proposal outlining benefits, risks, and life cycle costs of the proposed system to Corporate Engineering for evaluation.
- .9 To complement The City of Calgary Sustainable Building Policy goals and objectives.
- .10 The Design Guidelines for City of Calgary Funded Buildings take effect on January 1, 2021. The Guidelines apply to projects whose Prime Design Consultant contract is dated on or after January 1, 2021.

## 1.2 Guidelines Application

- .1 These guidelines are intended to supplement, and not to replace or duplicate, the requirements of codes including National Building Code, Alberta Edition, national codes (e.g. plumbing, gas, electrical), National Building Code Commentaries, CSA and industry design standards, and permits and inspections conducted by City of Calgary Building Services. Individual City business units and civic partners may also have their own specific design requirements, which consultants should obtain and abide to in addition to these guidelines.
- .2 These guidelines and receipt of any other information or documentation from City of Calgary employees does not in any way relieve consultants from the professional obligation to meet all applicable regulatory codes and standards.
- .3 Consult with Corporate Engineering where these guidelines are inappropriate for specific situations.
- .4 While these guidelines are organized in a manner most aligned with each discipline, coordination between the technical requirements in each discipline section is still required and some requirements may affect multiple discipline areas. It's the responsibility of the Coordinating Registered Professional on the project to ensure the appropriate level of coordination between disciplines is completed for the project.



## 1.3 Other City of Calgary and Civic Partner Design Requirements

Refer to the most current version of these other documents for requirements specific to certain types of related facilities, structures, and systems:

- .1 Advisory Committee on Accessibility - Access Design Guidelines.
- .2 Corporate Analytics & Innovation – CAD Standards.
- .3 Calgary Transit - Transit-Friendly Design Guide (for site layout and building access).
- .4 Calgary Transit – LRT Design Guidelines – Rev #2.
- .5 Calgary Transit – Design Guidelines Manual – Bus Rapid Transit.
- .6 Calgary Transit – Design Guidelines Manual – Light Rapid Transit.
- .7 Calgary Police Services – Crime Prevention through Environmental Design (CPTED).
- .8 Calgary Fire Department – Fire Station Design Standards.
- .9 Calgary Building Services - Fire Stopping Service Penetrations in Buildings.
- .10 Calgary Fire Department Finish Standards.
- .11 Calgary Parks – Urban Forestry Plan.
- .12 Calgary Parks – Our BiodiverCity.
- .13 Calgary Parks – Integrated Pest Management Plan.
- .14 Calgary Parks – Development Guidelines and Standard Specifications: Landscape Construction.
- .15 Climate Resilience – Calgary Climate Resilience Strategy.
- .16 Corporate Engineering and Energy – Sustainable Building Policy and Guidance Document.
- .17 Corporate Security, Door and Hardware Standards.
- .18 Facility Management – Space Planning Standards and Guidelines.
- .19 Facility Management – Furniture Standards.
- .20 Facility Management – Finish Standards.
- .21 IT Voice, Data and Wireless Infrastructure Standards (Network cabling).
- .22 Planning and Development – Master Development Agreement; Area Structure Plans; Centre City Guidebook; and Guidebook for Great Communities.
- .23 Planning and Development – Calgary Transportation Plan; Centre City Mobility Plan.
- .24 Planning and Development – Centre City Urban Design Guidelines.
- .25 Planning and Development – Urban Design Review Protocol and Framework.
- .26 Planning and Development – Bird Friendly Urban Design Guidelines.
- .27 Planning and Development – Calgary Heritage Strategy.

- .28 Planning and Development – Centre City Illumination Guidelines.
- .29 Roads – Standard Specifications Road Construction.
- .30 Roads - The Calgary +15 System Consolidation of Design Guidelines.
- .31 Utilities and Environmental Protection Land Information and Mapping - Design Guidelines for Development Permits and Development Site Servicing Plans.
- .32 Wastewater and Drainage – Effective Erosion and Sediment Control; as it pertains to the site associated with the facility.
- .33 Wastewater and Drainage – Stormwater Management and Design Manual.
- .34 Water Services – Standard Specifications Sewer Construction.
- .35 Water Resources – Standard Specifications Water Resources.
- .36 Waste & Recycling Services – Design Standards for the Storage and Collection of Recyclable Materials and Waste.
- .37 Physical Security Standard and Security Standard.

## 1.4 Codes, Standards, and Guidelines – General

The following codes, standards, and guidelines listed are applicable to all sections. Refer to the most current version of these documents for requirements.

- .1 National Building Code, Alberta Edition.
- .2 National Fire Code, Alberta Edition.
- .3 National Energy Code of Canada for Buildings (NECB).
- .4 Alberta STANDATA – Information related to interpretations, clarifications, recommended practices, or province wide variances on Codes and Standards.
- .5 City of Calgary – Bylaws, Building Regulation Advisories, Bulletins, and Variances.
- .6 Royal Architectural Institute of Canada – Canadian Handbook of Practice for Architects.
- .7 Canadian Parking Association – Technical Bulletins including Parking Facility Planning and Design Guidelines, Parking Facility Maintenance Manual, Revenue Control for Parking Facilities, and Parking Facility Security.
- .8 Canada’s Historic Places – Standards and Guidelines for the Conservation of Historic Places in Canada.
- .9 Rick Hansen Foundation – Rating Survey and Handbook.
- .10 Alberta Professional Engineers and Geoscientists of Alberta – Responsibilities for Engineering Services for Building Projects.





## Section 2 – Sustainability

2.1	Green Building Guidelines and Standards .....	6
2.2	Sustainable Buildings .....	6
2.3	The City of Calgary’s Sustainable Building Policy (The Policy) .....	6
2.4	Project Classification .....	7
2.5	Sustainability Principles .....	7
2.6	Early Planning .....	8

## 2.1 Green Building Guidelines and Standards

- .1 When appropriate, pursue green building certification(s) and follow suitable design guidelines and standards to reduce the operational and construction carbon emissions of the building. Examples may include but are not limited to, LEED v4 Reference Guide, Canada Green Building Council's Zero Carbon Building Standard, etc. Use the Sustainable Building Guidance Document and contact a Sustainable Building Policy Steward to determine applicable Green Building Guidelines and Standards.

## 2.2 Sustainable Buildings

- .1 Sustainable development refers to the ability to meet the needs of the current generation without restricting future generations from meeting their needs. As such, sustainable buildings shall seek to use energy, water, land and material resources efficiently and reduce negative impacts on the environment and human health.

## 2.3 The City of Calgary's Sustainable Building Policy (The Policy)

- .1 The City first started emphasizing the importance of sustainable buildings when The City's Sustainable Building Policy (The Policy) was piloted in 2003. The pilot was considered a success and Calgary City Council formalized The Policy in 2004. At the time of this document update, the latest update to The City's Sustainable Building Policy was approved by City Council April 29, 2019. If there are new updates to the Sustainable Building Policy and the Sustainable Building Guidance Documents, please refer to the most recent version for requirements that may supersede section 2.4-2.6 in this document.
- .2 The Policy applies to the planning, design, construction, operations, maintenance, renovation, and de-commissioning of all buildings that are City-owned and/or City-financed where The City provides a minimum funding contribution of 33 per cent of total project costs and The City contribution is equal to \$1,000,000 or more (not including project development costs, design costs, and land).
- .3 If the Policy does not apply to a City project, design the facility with the sustainability principles (see 2.5) in mind. Please contact Corporate Engineering & Energy for clarification and direction if needed.



## 2.4 Project Classification

- .1 Under the Sustainable Building Policy, City building projects are classified into five categories:
  - .1 New Construction: regularly occupied facility with a project floor area  $\geq 500 \text{ m}^2$ .
  - .2 Addition or Major Renovation: regularly occupied facility with a project floor area in scope  $\geq 500 \text{ m}^2$ . Additions with a new separate mechanical system are classified as New Construction.
  - .3 Affordable Housing: housing projects delivered by the Calgary Housing business unit or delivered by partner organizations receiving funding from The City.
  - .4 Interior Renovation: regularly occupied facility and project floor area in scope is  $\geq 500 \text{ m}^2$ . Under The Policy, Interior Renovations do not include building envelope or HVAC systems in scope. Projects that include these components are classified as a Major Renovation.
  - .5 All Other Building Projects: projects  $< 500 \text{ m}^2$  in scope and unoccupied facilities including those that house automated and industrial processes, transit stations and platforms and +15 structures. Industrial processes themselves are exempt.

## 2.5 Sustainability Principles

- .1 All projects are to evaluate and incorporate strategies to improve the following sustainability principles:
  - .1 Optimize for energy efficiency and conservation, specifically through passive design, thereby reducing and avoiding GHG emissions.
  - .2 Reduce potable water use through conservation and efficiency measures.
  - .3 Encourage the integration of green stormwater infrastructure.
  - .4 Maintain and improve biodiversity.
  - .5 Encourage occupant comfort, provide access, and maintain social wellbeing in design and operations.
  - .6 Select sites that have access to alternative transportation and consider the impact of site selection on the environment, people and the building.
  - .7 Design for resiliency to changing economic, social, and environmental conditions.
  - .8 Divert waste from landfills during construction, occupancy and demolition.

## 2.6 Early Planning

- .1 During the pre-design stage of a project the Strategic Planning Team / Project Sponsor must contact a Policy Steward and the two parties must review and complete the following sections in the Sustainable Building Guidance Documents in collaboration:
  - .1 Pre-Project Sustainability Requirements Checklist.
  - .2 Certification Selection Tool.
  - .3 Minimum Sustainability Performance Requirements.
- .2 During the pre-design phase the Strategic Planning Team / Project Sponsor and The Policy Steward will sign off on high level sustainability targets including the applicable Minimum Sustainability Performance Requirements and green building certification targets.
- .3 It is highly recommended that project teams establish a well-defined and thorough Owner's Project Requirements document prior to schematic design. This document is a working document that will guide design decisions.
- .4 It is recommended to review the Consultant Scopes of Work within the Sustainable Building Guidance Document when procuring consulting services for the Sustainability disciplines. Available consultant scopes of work include:
  - .1 Green Building Consultant.
  - .2 Commissioning Authority.
  - .3 Building Energy Consultant.



# Section 3 – Architectural

- 3.1 Architectural Design..... 10
- 3.2 Needs Assessment and Functional Programming ..... 10
- 3.3 Architectural Considerations ..... 11



## 3.1 Architectural Design

- .1 Design of City of Calgary civic buildings and spaces, from operational warehouses to recreation centres, is an opportunity to show the pride we have in our communities and our environment. Design can have an impact on individual well-being, and so good design of civic facilities can enrich the lives of all citizens.
- .2 Good design for civic buildings should balance resiliency and efficiency, be welcoming and secure for all people, be engaging and functional. Designs shall be responsive to their specific context and should work to provide a positive impact on the surrounding community. New and renovated building projects should be resilient, sustainable, fit for purpose and 'of their time' and as far as possible, designs should be considerate of being relevant for future generations and contribute to the history of the city as a whole.

## 3.2 Needs Assessment and Functional Programming

- .1 A clear Needs Assessment should be approved to support the project moving forward. This may be captured in other project documents such as project charters or business cases.
- .2 To ensure the design takes into account all requirements and considerations, it is important to start with an approved 'Functional Program'.
- .3 At minimum all rooms and functional spaces (including exterior spaces) required by each Business unit or Civic Partner or any other user of the building should be listed, with minimum expected areas, and adjacencies, as well as considerations to the sequence of spaces to be used and experienced.
- .4 Service spaces and circulation areas should also be included in this list, but may be included at this level as a percentage of other spaces, based on the building functions.
- .5 Where possible, full room data sheets should be completed, listing all requirements for each functional space. This will include adjacencies and access requirements, critical dimensions (clear heights etc.), type of users in the space, time of use, daylight requirements or avoidance. It will also include any special requirements for furnishings, security, finishes, electrical, lighting, HVAC, plumbing Fire suppression, communications or specialty equipment that would be an expectation for each room.
- .6 Descriptions of the activities that will take place within the room can help to fully define the spaces functional requirements so all of the design team members can ensure all functional expectations of the space are met early in the design process. Where possible, consideration for potential future uses beyond the initial programmatic uses should be considered to allow for program flexibility to accommodate future or changing needs over the lifespan of the building.

## 3.3 Architectural Considerations

- .1 Land Use/Zoning/Code Reviews: to be completed early in the process to ensure all requirements are able to be met. This is especially important for renovation and additions projects that should be reviewed to understand what permits are required, or if regulations or codes will impact the existing building.
- .2 Site Analysis: A full understanding of environmental (solar/wind/storm water, etc.) and urban factors (multi-modal transportation/shadows/adjacencies, etc.) should be reviewed in detail for each site to help inform the basis for the design.
- .3 Urban Design: All projects should consider their impact on the public realm, and where applicable, address the principles of urban design as defined by the Urban Design Guidelines. All new projects or additions should ensure the design choices clearly address the principles for a clear and strong presentation to the Urban Design Review Panel.
- .4 Concept Options: once Functional Program is approved, concept options should be discussed with the Business Unit and Civic Partners. 3 distinct options (of form and part, not only material types or glazing locations) should be reviewed. Inclusion of case studies or precedents should be included to support the design options discussed, bringing lessons from other spaces related to what options are out there, what has worked well and why.
- .5 Orientation and Massing: Site layout and building massing should consider all environmental impacts of the site, including: solar, wind, storm water and snow. Building orientation to be an efficient response to the environmental conditions, to allow for natural light, include passive energy efficiency strategies and consider the comfort of outdoor functional spaces.
- .6 Sustainability/Lifecycle/Building Performance: as required by the Sustainable Building Policy, a sustainable vision and goals should be set from the outset of the project, regardless of any certification requirements. This vision should clearly identify the performance objectives related to energy and water reductions. The lifecycle of the building and all components should be considered throughout the design process and discussed in detail with the operations staff. Design decisions that impact lifecycle goals and costs should not be made without understanding both the capital and operating implications of those decisions.
- .7 Basis of Design: Concepts should include early in the design, all 'parti-level' elements that may be relevant to the specific project. This may include but not be limited to spatial hierarchy, building cores, interior circulation, public/private zones, solidity/transparency, views, juxtapositions and overall design intent and objectives. These should be clearly articulated to ensure that future design decisions are made with these elements in mind as the project progresses.
- .8 Accessibility: The Access Design Standards, more than code required minimums, should be met on every new building project. Renovations and additions should also meet the majority of these standards for all portions that are possible within reasonable costs. It is important to reiterate that accessibility is not only for wheelchair users, but for citizens and staff of varying abilities, including hearing and vision challenges, and that including these standards eases access for many others as well.
- .9 CPTED: Crime Prevention Through Environmental Design principles should be considered early in the design process and be measured throughout the project to ensure those principles important for each project are carried through. This may aid in meeting some development permit requirements later in the project.

- .10 Site and Landscape: the site layout and landscape areas should be appropriate for the context of the surrounding community, while linking to the urban design elements indicated above. Soft landscape elements should incorporate species that are appropriate to the macro and micro climate they are located in and consider ease of maintenance. Wherever possible an enhancement to the natural ecology and biodiversity of the site should be considered. All required site furniture should be accommodated, including garbage bins, benches, bike racks, and these functional items should not impede circulation. Accommodation for appropriate storm water and irrigation should be included where appropriate. Specific consideration for snow piling locations on site that will not harm landscaped areas should be included. Inclusion of sustainable hard landscape materials should be attempted as much as possible.
- .11 Entry: the entries for buildings should be obvious and welcoming to users of the facilities. Consideration for where users are coming from should be included in the site orientation studies so that entrances are located in appropriate locations for ease of use from all modes of transportation (vehicle/transit/pedestrian/bicycle).
- .12 Exterior Circulation: multi-modal (vehicle/bicycle/pedestrian) circulation patterns should be accommodated for from outside the site boundaries to within the site layout and clearly support the entry locations chosen. Safety between all modes should be considered. Circulation on the site should be appropriate and connect to the larger community circulation network. Circulation diagrams for all modes should be included as part of early design discussions, and should include specialty vehicle circulation when required (large waste vehicles or other vehicles required for the building functions).
- .13 Exterior Building Materials: all exterior materials should be chosen for low-maintenance and durability. Building materials next to walkways and drive areas where snow-removal will take place should pay special attention to durability. Materials should also be appropriate to the community context. For additions and renovations, materials should complement the existing, and only attempt to 'match' existing when the same product is still available.
- .14 Interior Circulation: especially important for large complex building functions, circulation between internal spaces should be clear and follow a simple, logical pattern where appropriate and may include strategies such as daylighting to help orient the user. All attempts should be made to ensure main navigation of a building is intuitive and not require the use of excessive signage. However if signage is required, a specialist wayfinding consultant may be beneficial for larger or complex facilities. If possible, circulation that includes the opportunities for active participation (such as a convenience stairway) should be encouraged.
- .15 Interior Building Materials: should be durable and have low VOC content. Materials should be recycled, recyclable and sustainable wherever possible. Consideration to all detailing that will impact maintenance and cleaning should be discussed with building operators (e.g., sealing of finished concrete floors).
- .16 Future Maintenance: Access for maintenance and cleaning operations tasks should be considered in all interior and exterior areas. Specific consideration for double height interior spaces that may need lifts or scaffolding to complete required maintenance and cleaning, (e.g., change of light bulbs in large atrium spaces, or window washing both interior and exterior, may require higher floor loading to accommodate a scissor lift to access the appropriate locations.) Including the end operator in all decisions related to future maintenance tasks.
- .17 Service Space Access: all services spaces (mechanical, electrical, communications rooms) should ensure appropriate access on all required sides of equipment. Consideration for access in/out of service spaces for repair and replacement should be discussed with building operators.



- .18 Fall Protection: coordinate with the client and building operator on whether there is a preference for interior (e.g., hatch) versus (e.g., ladder) roof access, and whether tie-off points (roof anchors) will be required. Refer to Section 8.2.9 for further structural requirements if roof anchors are included.
- .19 Access Control, Doors, and Hardware: be sure to review the Corporate Security standards as it relates to access control, doors, and hardware. As some of the systems can be complex to co-ordinate it is recommended that early reviews/consultation with a representative from corporate security is taken early in the process. Some co-ordination challenges typically include mag-locks at fire exits with push bars, and release of mags with fire alarm. Lock-sets that accommodate appropriate cores also need to be coordinated with the Corporate Security standards. Special attention should be given to coordination of access control, physical security, door and hardware details, code requirements for exiting and accessibility (clause 3.3.8) requirements.
- .20 Architectural Involvement Throughout: Ensure that design decisions from early stages are clearly documented so that as changes are requested during the project lifecycle, impacts on the architectural design are considered. It is especially important to ensure that changes during construction phase are considerate of the original intent. It is encouraged to include the project architect throughout the construction phase.
- .21 Building Code Summary: At high level Building Code Summary is to be included on design drawings as appropriate for phase of design (at minimum this should include occupancy type, areas for all buildings/ floors, and overall combustibility requirements).
- .22 Acoustics: Refer to Section 9 - Acoustics and Vibration.
- .23 Innovation: To achieve innovation it is important to document the innovative strategies early in the project and review with the business unit or civic partner for incorporation. It is also imperative to document the project successes and lessons learned to achieve innovative strategies for future use. There are 3 parts of innovation that should be considered early for inclusion in projects:
  - .1 Organizational innovation is supported by flexible spaces that promote the convergence between diverse perspectives and disciplines.
  - .2 Project innovation is encouraged when it helps advance the desired goals/functional outcomes that underlie the more specific aspects of these guidelines.
  - .3 Process innovations are encouraged to promote more effective collaboration and timely decision making.



# Section 4 – Civil

- 4.1 Retaining Walls..... 15
- 4.2 Grade Structures ..... 15

## 4.1 Retaining Walls

- .1 These Guidelines apply to retaining walls designed and constructed as part of a building or site development for a building project. For other transportation-related retaining walls, refer to City of Calgary Guidelines for Bridges & Structures and coordinate with Transportation Infrastructure - Bridges and Structures.
- .2 For retaining walls higher at any point than 1.0 m, engage a geotechnical engineer to provide a geotechnical investigation and report that includes information for design and construction, with the recommendations sealed and signed by a Professional Engineer experienced in this type of structure.
- .3 For retaining walls higher at any point than 1.0 m, do not use modular blocks with only keying between blocks where there is potential for frost heave, subgrade settlement, differential settlement or other vertical movement that could disrupt keying.
- .4 Retaining wall design considerations: soil pressure; hydrostatic pressure; adjacent structure surcharge loads; adjacent traffic surcharge loads; potential for future slope build-up behind wall; and potential for excavation (e.g., for road or sidewalk replacement, utilities, or plantings) behind wall if tiebacks/deadmen/straps are utilized or in front of wall if passive resisting soil pressure is utilized.
- .5 Refer to the Structural Section in these Guidelines for other considerations and requirements.

## 4.2 Grade Structures

- .1 All exterior pedestrian surfaces to have a minimum 2% drainage slope.
- .2 Allow for long-term settlement of excavation backfill and avoidance of consequent back-drainage in design of grading for sidewalks, plazas, etc., for instance adjacent to basements, trenches, and retaining walls. Consider a bridging structural slab in those areas.
- .3 Refer to the Structural Section in these Guidelines for other considerations and requirements.





# Section 5 – Building Envelope

- 5.1 Codes and Standards ..... 17
- 5.2 Design Principles ..... 17
- 5.3 Thermal Performance ..... 18
- 5.4 Roofs ..... 18
- 5.5 Roof Drains and Rainwater Leaders ..... 19
- 5.6 Detailing ..... 20
- 5.7 Durability ..... 21

## 5.1 Codes and Standards

- .1 New design, additions, upgrades and repairs to conform to or exceed the latest edition of the following codes and standards in addition to those listed in Section 1.4:
  - .1 CAN/CSA-A440 Windows; and Special Publication A440.1 User Selection Guide to CSA Standard CAN/CSA-A440 Windows.
  - .2 AAMA/WDMA/CSA/101/I.S.2/A440 Standard/Specification for Windows, Doors and Unit Skylights.
  - .3 AAMA/WDMA/CSA/101/I.S.2/A440S1 Canadian Supplement to AAMA/WDMA/CSA/101/I.S.2/A440 Standard/Specification for Windows, Doors, and Unit Skylights.
  - .4 CAN/CSA-A440.2 / A440.3 Energy Performance of Windows and Other Fenestration Systems / User Guide to CAN/CSA-A440.2 Energy Performance of Windows and Other Fenestration Systems.
  - .5 CAN/CSA-A440.4 Window, Door, and Skylight Installation.
  - .6 CSA-S478 Durability in Buildings.
  - .7 ASTM E779 – Standard Test Method for Determining Air Leakage Rate by Fan Pressurization.
  - .8 AAMA 501.2 Quality Assurance and Diagnostic Water Leakage Field Check of Installed Storefronts, Curtain Walls, and Sloped Glazing Systems.
  - .9 The AAMA 502 Voluntary Specification for Field Testing of Newly Installed Fenestration Products.
  - .10 The ASTM E 1105 – Standard Test Method for Field Determination of Water Penetration of Installed Exterior Windows, Skylights, Doors, and Curtain Walls.
  - .11 The AAMA 503 – Voluntary Specification for Field Testing of Newly Installed Storefronts, Curtain Walls, and Sloped Glazing Systems.

## 5.2 Design Principles

- .1 Design a building envelope system for all occupied facilities and other facilities requiring separation from the exterior environment and/or energy efficiency by limiting air, moisture and heat exfiltration and infiltration. There may be some facilities (e.g., storage or equipment sheds) where a full building envelope system is not required: consult with the client business unit or civic partner.
- .2 The building envelope design approach generally preferred is the Pressure Equalized Rain Screen Insulated Structure Technique (PERSIST), comprising:
  - .1 Exterior rain screen cladding with drainage openings, covering an air space pressure-equalized with the exterior. Air space to be minimum 25 mm wide, allowing for adjoining material and mortar installation tolerances, and compartmentalized to maximum 4 m dimensions.
  - .2 Insulation, located exterior to structural components where practical, and immediately exterior to an air barrier and vapour retarder system.
  - .3 Air barrier and vapour retarder systems (which may be combined into one system), exterior to structural components where practical.
- .3 When retrofitting existing envelope systems careful consideration is required of the existing wall assemblies and integration with new systems. Consider hygrothermal modelling to identify appropriate condensation locations, climactic conditions, interior humidity levels and the integration with the cladding system.

## 5.3 Thermal Performance

- .1 Envelope for a heated facility is to be minimum effective overall RSI 7.25 (R41) (at minimum for tapered thicknesses) for roofs, and RSI 3.52 (R20) for exposed perimeter foundation elements. Wall assembly R-value targets are to be established by the consultant in coordination with The City. If listed R values are impractical for a specific application or construction type, please contact Corporate Engineering for clarification and direction.
- .2 The overall effective R-value is to, as described in NECB 2017-Part 3.1.1.7, take into account thermal breaks such as glazing transitions, Z-girts, framing materials, junctions and edges, etc.
- .3 Provide protection to insulation or use non-susceptible insulation material where it may be exposed to gasoline or other chemicals causing deterioration (e.g., below an upper parking area) or to sunlight.
- .4 Check against incompatibility of materials (e.g., plasticized PVC and self-adhering rubberized asphalt flashings).

## 5.4 Roofs

- .1 For flat or low-slope roofs, a 2-ply modified bitumen membrane is preferred for durability. Consult with client business unit or civic partner if proposing an elastomeric (e.g., TPO, PVC, and EPDM), built-up or other membrane: durability is arguably less, and surfaces can be unsafely slippery for maintenance access when wet or frosty. Provide a supplementary protective surface for any high-volume pedestrian traffic.
- .2 A roof warranty should be included for all roof products that lasts 15 years and includes labour and materials. If an ARCA Warranty Certificate is included ensure the operating BU will inspect the roofing annually to meet warranty maintenance requirements.
- .3 On roof plan(s) indicate high and low point elevations, drainage directions, backslopes, crickets, all drains, all other roof penetrations (e.g., vents, fans, RTU ducts), and all roof-mounted equipment.
- .4 Provide minimum four per cent roof drainage slopes, including in valleys and across parapets.
- .5 Minimum roof slopes for other roofing materials to be as follows:
  - .1 1:3 for triple tab asphalt shingles; to be minimum 25-year interlocking.
  - .2 1:2.4 for cedar shingles.
  - .3 1:2 for cedar shakes.
- .6 Provide roof overflow scuppers where there are no internal drains or where there is no alternate flow path for water from a potentially blocked drain to another drain without ponding overload. Design scupper size to prevent ice blockage. Extend scuppers minimum 50 mm beyond building face and with drip edge to avoid risk of draining into wall cavity and avoid draining onto pedestrian routes.
- .7 Avoid controlled-flow roof drainage design where possible.
- .8 Metal roofing is to be considered to be water-shedding only and requires a waterproof membrane and drainage below.
- .9 Form roof drainage slopes with the structure instead of with tapered insulation, except for backslopes and crickets.



- .10 Provide minimum 300 mm high curbs at all roof penetrations other than drains.
- .11 Attics to be unheated, unless by consultation with the client business unit or civic partner.
- .12 Where re-roofing is required prior to its normal life expectancy, investigate the reasons for premature failure prior to re-roofing design, and include remedial measures in the re-design to prevent reoccurrence (e.g., Ice damming, inadequate attic venting, poor flashing, etc.).
- .13 Do not set mechanical equipment, pipe supports, or concrete pavers directly on roofing: utilize minimum 350 mm high curbs for mechanical equipment, or support on high-density polystyrene insulation. Refer to Mechanical guidelines for minimum clearance off roof for large units.
- .14 Roof-level glazing is preferred to be by vertical clerestory. Sloped skylights and glazing to be avoided except by consultation with the client business unit or civic partner. Where skylights or sloped glazing are incorporated:
  - .1 Slope glazing minimum 30 degrees from horizontal.
  - .2 Air seal connections to curbs and adjacent walls to be fully accessible during construction.
  - .3 Water that enters the glazing rabbet to be contained within the rabbet and to drain back to the exterior in all seasons without contacting caulked joints or seals.
  - .4 Provide an interior condensation gutter system, drained where warranted by a high-humidity interior environment.
  - .5 Glazing seals to be dry mechanically keyed, and not utilizing caulking or other sealants.
  - .6 Glazing to be minimum heat-strengthened exterior light and laminated interior light for safety.
- .15 Consider electronic leak detection with capability of remote monitoring on low slope roofs, consultation with the client business unit or civic partner is required for specific requirements.
- .16 Do not use spray foam insulation in the attic and roofing assemblies.
- .17 Do not construct balconies, patios or terrace over the living areas unless 2-ply roofing with drainage board and membrane protection is used.

## 5.5 Roof Drains and Rainwater Leaders

- .1 Provide a removable observation-access panel in fixed ceilings below roof drains.
- .2 Locate rainwater leader outlets to avoid draining onto pedestrian and vehicle areas, and to avoid draining or backflow against foundations.
- .3 Downspout extensions to be designed to prevent damage or removal during grass cutting or by vandalism (e.g., could use one or series of embedded precast concrete splash pads).
- .4 Ensure that rainwater leaders are not subject to freezing within the building (e.g., within perimeter unheated enclosed chases).
- .5 Please indicate sizes of rainwater leaders and gutters on the drawings.

## 5.6 Detailing

- .1 Detail to ensure that:
  - .1 Water, snow and ice can shed completely from exterior surfaces.
  - .2 Draining water and falling snow and ice do not endanger pedestrians or property.
  - .3 Roof ice damming is minimized.
  - .4 Water cannot enter building components as a result of snow and ice build-up (e.g., upturn membrane minimum 300 mm at upstand walls), or of wind (e.g., at unprotected eaves or open wall assemblies adjacent to roof edges).
- .2 Fasteners and connections providing vertical and lateral support to cladding are corrosion-resistant for the design life of the building.
- .3 To avoid condensation on interior surfaces, buffer high-humidity interior spaces from the building envelope face or provide adequate ventilation against the interior envelope surface (e.g., at swim pool area glazing), and avoid thermal bridging (e.g., at exposed structural framing).
- .4 Air barrier and vapour retarder continuity and installation methods and sequencing must be fully described on design drawings. Provide large-scale and perspective details where needed to explain intent, in particular at:
  - .1 Window and door frames.
  - .2 Services penetrations.
  - .3 Projecting structural members.
  - .4 Wall/roof/parapet, wall/floor and wall/wall intersections.
  - .5 Deflection and control joints in architectural/structural framing.
  - .6 Galvanic isolation joints between dissimilar materials.
- .5 Require and review mock-up or prototypical wall and roof sections with the general contractor and involved trades to ensure that envelope material laps, tie-ins to adjacent materials, and sealing around projections are demonstrated and achievable.
- .6 Concealed spaces to be provided with access hatches. Unheated concealed spaces to be vented to the exterior.
- .7 Provide a prefabricated sill pan or other means to drain to exterior any water that infiltrates windows and jambs.
- .8 Insulation to be in direct contact with the air barrier and to be mechanically fastened to secure substrate. Fasteners must demonstrably avoid compromising the air barrier and vapour retarder integrity.
- .9 Windows to meet CAN/CSA A440-series Standards: minimum requirement is double-glazed with at least one low-e surface. Do not use post-applied tinting films.
- .10 Exterior access stairs and ladders to have framing and connections designed against corrosion for the design life of the building.
- .11 Avoid using bentonite as a joint filler in thin or lightly-reinforced slabs, as it can spall joint edges upon expansion.

## 5.7 Durability

- .1 The building envelope system to be of durable construction to meet CSA S478, that responds to the environmental and traffic conditions for the full life expectancy of the structure. Systems that are proven within temperate climate regions similar to those found in Calgary with frequent freeze-thaw cycles should be prioritized. Clarity of specifications for installation is imperative, with appropriate inspections and/or testing related to the type of systems chosen encouraged.
- .2 Polyethylene vapour barrier and friction-fit batt insulation are not best-practice building envelope materials, especially for non-residential construction.
- .3 Exterior surface material and texture considerations to include resistance to vandalism and accidental impact (e.g., balls, pucks), resistance to and removal of graffiti (e.g., masonry sealer), and resistance to ultraviolet radiation embrittlement, deterioration and chalking. Choose EIFS only after careful consideration of the above-noted risks.
- .4 A minimum of weekly site review and a follow-up report is required during the envelope construction.
- .5 As a minimum, it is recommended that envelope is tested through the following 3 steps:
  - .1 Infrared scan of the envelope including roof.
  - .2 Air leak testing using ASTM E779.
  - .3 Water penetration test using ASTM 1105.



# Section 6 – Structural

- 6.1 Codes and Standards ..... 23
- 6.2 Drawings Information ..... 24
- 6.3 Design Life ..... 26
- 6.4 Loads and Analysis ..... 26
- 6.5 Serviceability Requirements ..... 27
- 6.6 Materials ..... 28
- 6.7 Geotechnical Considerations ..... 30
- 6.8 Delegated Design ..... 30
- 6.9 Parking Areas ..... 30
- 6.10 Detailing ..... 31
- 6.11 Construction Inspection and Testing Agencies ..... 33
- 6.12 Antenna-supporting Towers and Structures ..... 34
- 6.13 Acoustics and Vibration ..... 34



## 6.1 Codes and Standards

- .1 In addition to the documents listed in Section 1.4, new design, additions, upgrades and repairs to conform to or exceed the latest edition of the following codes and standards generally, plus those specifically referenced in following clauses:
  - .1 User's Guide – NBC: Structural Commentaries (Part 4 of Division B).
  - .2 CAN/CSA-A23.1 / A23.2 Concrete Materials and Methods of Concrete Construction Methods of Test and Standard Practices for Concrete.
  - .3 CSA-A23.3 Design of Concrete Structures.
  - .4 CSA-A23.4 Precast Concrete - Materials and Construction.
  - .5 CSA-A165.1 Concrete Block Masonry Units.
  - .6 CSA-A165.2 Concrete Brick Masonry Units.
  - .7 CSA-A165.3 Prefaced Concrete Masonry Units.
  - .8 CSA-A179 Mortar and Grout for Unit Masonry.
  - .9 CSA-A283 Qualification Code for Concrete Testing Laboratories.
  - .10 CSA-A370 Connectors for Masonry.
  - .11 CSA-A371 Masonry Construction for Buildings.
  - .12 CSA-A864 Guide to the Evaluation and Management of Concrete Structures Affected by Alkali-Aggregate Reaction.
  - .13 CAN/CSA-G30.18 Billet-Steel Bars for Concrete Reinforcement.
  - .14 CAN/CSA-G40.20 / 40.21 General Requirements for Rolled or Welded Structural Quality Steel/Structural Quality Steel.
  - .15 CAN/CSA-G164 Hot Dip Galvanizing of Irregularly Shaped Articles.
  - .16 CAN/CSA-O86 Engineering Design in Wood, and O86S1 Supplement No. 1.
  - .17 CSA-O121 Douglas Fir Plywood.
  - .18 CAN/CSA-O122 Structural Glued-Laminated Timber.
  - .19 CAN/CSA-O141 Softwood Lumber.
  - .20 CSA-O151 Canadian Softwood Plywood.
  - .21 CSA-O153 Poplar Plywood.
  - .22 CAN/CSA-O177 Qualification Code for Manufacturers of Structural Glued-Laminated Timber.
  - .23 CSA-O325 Construction Sheathing.
  - .24 CSA-O437.0, O437.1, O437.2 CSA Standards for OSB and Waferboard.
  - .25 CAN/CSA-S16 Limit States Design of Steel Structures.
  - .26 CAN/CSA-S136 North American Specification for the Design of Cold-Formed Steel Structural Members.
  - .27 CAN/CSA-S269.3 Concrete Formwork.
  - .28 CSA-S304.1 Design of Masonry Structures.
  - .29 CSA-S350 Code of Practice for Safety in Demolition of Structures.

- .30 CSA-S448.1 Repair of Reinforced Concrete in Buildings.
- .31 CSA-S478 Durability in Buildings.
- .32 CSA-W47.1 Certification of Companies for Fusion Welding of Steel.
- .33 CSA-W55.3 Resistance Welding Qualification Code for Fabricators of Structural Members Used in Buildings.
- .34 CSA-W59 Welded Steel Construction (Metal Arc Welding).
- .35 CSA-W178.1 Certification of Welding Inspection Organizations.
- .36 CSA-W178.2 Certification of Welding Inspectors.
- .37 CSA-W186 Welding of Reinforcing Bars in Reinforced Concrete Construction.
- .38 PCI MNL-116 Manual for Quality Control for Plants and Production of Precast and Prestressed Concrete Products.
- .39 PCI MNL-117 Manual for Quality Control for Plants and Production of Architectural Precast Concrete Products.
- .40 CSA- S850 Assessment of Blast Resistant Buildings.
- .41 CSA-Z259. <http://www.infrastructure.alberta.ca/Content/docType486/Production/TB-036.pdf>
- .42 ASCE 19-16 - Structural Applications of Steel Cables for Buildings.

## 6.2 Drawings Information

- .1 Drawings shall include geotechnical design parameters for the structure and/or each adjacent building (where necessary) as applicable including but not limited to:
  - .1 Reference to the geotechnical report on which the foundation design is based upon including title, date of issue, file number and company name of consultant who prepared the report.
  - .2 Site class.
  - .3 SLS & ULS soil bearing pressures.
  - .4 SLS & ULS skin friction.
  - .5 Required sulphate resistance.
  - .6 Geotechnical resistance factors.
  - .7 Geotechnical parameters including spring constants.
  - .8 Minimum pile diameter and length.
  - .9 Minimum frost depth.
- .2 Drawings shall include structural design parameters including but not limited to:
  - .1 The edition of building code and standards used for design and/or construction.

- .3 Drawings shall include loading criteria for all occupied areas at grade and above, including the following parameters. Use load maps where required to present loading clearly where dedicated areas on a floor plate requires different loading criteria.
  - .1 Live loads (LL).
  - .2 Superimposed dead loads (SDL).
  - .3 Self-weight dead loads (DL).
  - .4 Climatic data.
  - .5 Building Importance Factors.
  - .6 Concentrated loads associated with specific area loads.
- .4 Drawings shall include climatic loading parameters shall be Indicated on load maps or the roof plan, including:
  - .1 Base and accumulated snow loads.
  - .2 Ponding loads.
  - .3 Wind loads including uplift.
  - .4 Seismic loads.
- .5 Indicate the lateral force resisting system(s) incorporated in the building including SFRS type and modification factors.
- .6 Indicate on load maps or floor plans where changes in loading criteria may occur within a space, such as high density storage locations, egress or equipment routes.
- .7 Indicate ULS loading and deflection limits considered for the building envelope and cladding systems.
- .8 Indicate ULS loading considered for OH&S requirements such as fall protection. Roof anchor layouts and design loads shall be noted on the plans. Permanent rooftop anchors to be designed in accordance with CSA Z259 requirements.
- .9 Indicate load allowance considered on roofs for future solar photovoltaic array installation. Array areas shall be shown on the roof plan and/or load map.
- .10 Use a minimum drawing scale of 1:200 for plans and 1:100 for sections and details.
- .11 Indicate LL and DL vertical and horizontal deflection limits. Indicate any specified cambers on the plans.
- .12 Indicate expected vertical, horizontal and rotational movement expected at expansion joints.
- .13 Indicate vibration acceleration limits for the main intended use of the building, any special areas due to the building's functional requirements and/or equipment needs.
- .14 Indicate on plans any provisions for future additions including but not limited to knock out panels for future openings and load allowance for future support.
- .15 Indicate required material properties and finishes for exposed and non-exposed conditions.
- .16 Indicate components requiring delegated design, including design parameters such as loading, unique load combinations, shoring movement, vibration acceleration limits and adjacent ground movement limits.

- .17 Indicate assumptions and requirements for any special construction procedures and/or temporary stability measures.
- .18 Indicate areas and load parameters for green roof/patio areas and if they are fully or partially accessible.
- .19 For antenna-supporting towers and structures indicate the following:
  - .1 Items listed in Appendix A of CSA Standard S37 Antennas, Towers, and Antenna-Supporting Structures.
  - .2 Corrosion protection measures and details for all required components.
  - .3 Grounding configuration and information.
  - .4 Access climbing and safety information (ladders, platforms, cages, fall-arrest devices).

## 6.3 Design Life

- .1 Design life of new structures to be 75 years - or “Long life” per CSA-S478 Guideline on Durability in Buildings.
- .2 Consider the structure location and site specific requirements when determining the design life of the building. For example, structures located in flood plains should include appropriate design parameters to ensure the building life for expected 1:100 conditions.

## 6.4 Loads and Analysis

- .1 Confirm with The City where buildings may be used for post-disaster shelters such as community, recreation and social centres and thus categorized as High Importance.
- .2 Design a designated area on all floors used as Office Areas to accommodate file storage and/or high density records storage for a minimum Live Load of 4.8 kPa plus partition load unless otherwise approved. Also consider other future high loading usage requirements and include loading criteria for any defined owner project requirements for future known uses and flexibility for future known uses.
- .3 Mechanical units and other equipment shall be considered as live loads and not dead loads. Indicate location and weight of the units on the plans.
- .4 Unless otherwise directed, design roof Snow loading to include drift and sliding build-up caused by potential adjacent buildings or tree belts, and design wind exposure factor is not to be reduced below 1.0.
- .5 Roof water ponding design in multi-bay situations to take into account where Gerber-beam design, unequal spans or other conditions might allow a negative-deflection.
- .6 Situation in adjacent bays to contribute water to the ponded bay and where a roof drain may be plugged. Detail the design ponding loads on the design drawings, if a more severe case in any location than design snow-plus-rain loading.
- .7 Confirm with The City the potential for future installation of solar photovoltaic arrays or other similar system, and include resultant loading from the arrays including panels, ballast, snow accumulation and wind uplift. New construction designs shall always include a 0.5 kPa allowance for flexibility to include future solar arrays.



- .8 Skylights located on green roof/patio areas that are climbable shall be designed for live load in addition to the applicable snow, rain, superimposed and dead loads.
- .9 Design shall include considerations for new installation and future replacement of mechanical and other large or heavy equipment. This may entail knock-out wall, roof and/or floor panels, removable roof panels, and/or heavy loading on floor travel paths. Indicate all areas with increased loading, knock out panel and travel path requirements on the plans. Indicate lift-points and capacity for removal/replacement of mechanical units and other equipment for maintenance purposes.
- .10 In mechanical and other similar equipment rooms, allow for minimum 100 mm thick concrete housekeeping pads at any location on the floor.
- .11 For major renovations of existing buildings, investigate the safety and adequacy of the existing structure(s), supporting conditions and non-structural attachments where the existing conditions require modification. Where the existing structural lateral force resisting system is affected by new or modified conditions, confirm with the Authority Having Jurisdiction whether upgrades are required to meet current wind and seismic conditions. Modifications to the structure due to changes in existing conditions shall comply with current building code requirements.
- .12 For minor renovations and lifecycle replacements, ensure all modifications are compatible with the existing structure conditions and materials. All modifications to the structure due to changes in existing conditions shall comply with current building code requirements.
- .13 Design calculations shall be made available to The City if requested.
- .14 Durability shall be considered in all aspects of design including the structural system, material selection, details and protective measures.
- .15 Design and detailing shall consider strength, durability, serviceability and maintenance. Structural connections requiring 'slip-critical' design should be identified.
- .16 Consider blast design where required by Owner Project Requirements or areas storing large quantities of chemicals, fuel, or as required due to building classification. Blowout panel design shall be restrained to prevent personal injury.
- .17 Use caution while hanging heat producing elements (such as unit heaters, lights etc.) near the structural members as they can cause additional thermal stresses in the members which they are not designed for. Consult with structural engineer for verification of loading and effects on structural members.
- .18 Use commentary L from National Building Code while evaluating existing buildings.

## 6.5 Serviceability Requirements

- .1 Provide minimum 130 mm thick concrete mechanical room floors to minimize structural vibration. Do not use unbonded post-tensioned concrete reinforcement.
- .2 Provide 100 mm thick concrete housekeeping pad for major mechanical and electrical equipment.
- .3 Design floor structure to prevent transient footstep induced vibration from exceeding the annoyance threshold.
- .4 Provide special attention to vibration control where synchronized and/or resonant activities could occur, such as aerobics and other rhythmic or dynamic loading.

- .5 Ensure rooftop mechanical equipment is located on a stiff portion of roof structure to avoid resonance problems.
- .6 Provide acoustic and/or vibration isolation where required for functional program requirements or equipment needs.
- .7 Ensure the effects of vibration are coordinated with the performance and tolerances of the specified curtain wall and/or glazing systems.
- .8 Camber structure to minimize long-term deflection impacts on cladding and prevent appearance of sagging.
- .9 Control and expansion joints shall be incorporated at appropriate locations to accommodate anticipated movement within the building and with respect to the adjacent buildings and/or structures.

## 6.6 Materials

- .1 Consider constructability in the design of the structure including material choices, construction sequencing, and impact to surrounding vehicle and pedestrian traffic, and seasonal effects.
- .2 Materials selection shall consider lifecycle costs, durability, serviceability, sustainable objectives, and maintenance.
- .3 Provide lifecycle and replacement costs and estimated theoretical life information where requested.
- .4 Do not use un-bonded post-tensioned concrete reinforcement.
- .5 Gerber systems do not allow sufficient flexibility for future modifications such as mechanical unit upgrades on roof structures; use other framing systems.
- .6 Epoxy-coated reinforcement is not an acceptable means of protecting reinforcement; use either galvanized reinforcement or stainless steel.
- .7 Exposed concrete surfaces to be high quality and consistent in colour and texture, and shall be resistant to corrosion caused by exposure to the environment and de-icing salts.
- .8 High performance concrete should be considered in all exposed concrete elements within splash zones of the roadway (10.0 m horizontal and 3.0 m vertical).
- .9 Do not use high-strength steel bars (e.g., Dywidag) where there may be possible exposure to standing water, or located within un-ventilated spaces, areas with a high level of condensation, humidity or corrosive environments.
- .10 Where galvanized reinforcing steel is used, the chairs, tie wires, nuts, bolts, washers, other devices and miscellaneous hardware used to support, position, or fasten the galvanized reinforcement shall also be galvanized, plastic, or plastic-coated. Contact points between galvanized and black reinforcing steel shall be separated by a non-conductive material such as rubberized pads or rubber hose rings.
- .11 Ensure all connections and finishes of dissimilar materials are compatible or isolated to prevent galvanic corrosion.

- .12 Where concrete curbs, walls, slabs, etc. are placed on previously cast components, these elements shall have additional reinforcement of small size and spacing to mitigate relative shrinkage cracking. Any finishes such as tiling or waterproofing, etc. shall be applied in a manner that will allow for relative shrinkage to the base material.
- .13 Supplementary cementing materials (SCM's) such as fly ash, metakaolin and silica fume are strongly encouraged as partial replacement for concrete cement where performance may be maintained.
- .14 To minimize shrinkage and curling of slabs on grade, and to enable inserts, do not specify concrete strength stronger than minimum required for slab performance, avoid air entrainment of interior slabs, and consider a pre-wetted sand blotter between underside of slab and vapour barrier.
- .15 Provide protection for components in areas that may be exposed to spills or leaks of corrosive solutions (e.g. mechanical room floors supporting brine tanks or water softeners), standing water, and unventilated spaces with a high level of condensation or humidity or corrosive environments.
- .16 Exposed structural steel components such as columns, guardrails, ladders, platforms, sump covers, supporting frames, base plates, anchor rods, and bolts subject to frequent application or spray of de-icing salts, or which are located in areas of continuing moisture exposure such as sumps; are to be constructed of galvanized steel, stainless steel, cathodically-isolated aluminum or primed and painted with high quality coatings. Site-welding is to be avoided where possible condensation, humidity or corrosive environments may exist.
- .17 Notch tough steels are to be used for all fracture critical elements exposed to the elements and subjected to unheated service conditions.
- .18 All fasteners and components for the attachment of miscellaneous steel components such as signage, traffic signals, etc., shall be hot-dip galvanized.
- .19 For all HSS and pipe members subject to freezing provide:
  - .1 Cap plates.
  - .2 Drain holes at lowest point.
  - .3 Seals (e.g., neoprene) around all fastening penetrations exposed to water.
  - .4 Minimum Charpy V-Notch toughness of 27 Joules at -20°C.
- .20 For galvanized structural steel including pipe and plate steel shapes (not including reinforcing bars), specify provision of a 10-year guarantee against corrosion or defects in the galvanizing quality or workmanship. Under the guarantee, the supplier will repair or replace (including shipping) any components that fail during the guarantee period.
- .21 Design wood framing to allow for longitudinal shrinkage of sawn lumber floor joists, studs and columns without causing noticeable unevenness or sloping from adjacent non-shrinking components such as engineered wood members, masonry, cast-in-place concrete, and structural steel members.
- .22 Consider shrinkage between dissimilar materials such as concrete, steel, masonry, and wood.
- .23 Consider long term creep of wood framed structures, particularly in trusses.
- .24 Do not use glulam members in the exterior environment.

## 6.7 Geotechnical Considerations

- .1 Refer to the Civil section for surface, subsurface and retaining wall requirements.
- .2 Where a utility enters a structure, provide an oversized, sleeved and waterproofed opening and/or utility-support “bridge” to accommodate relative settlement and movement.
- .3 Ensure the static and dynamic loads of the building imposed on adjacent structures are resolved to the foundations.

## 6.8 Delegated Design

- .1 Where design of temporary, permanent or non-proprietary components by the General and/or Sub-Contractors and/or Suppliers is required, design drawings, specifications and/or calculations signed and sealed by a Professional Engineer registered in the Province of Alberta shall be submitted to The City and The City’s consulting team for review and comment.
- .2 The Professional Engineer responsible for the delegated design is to perform site/shop reviews to ensure that construction satisfies any relevant design requirements and standards, and shall copy their reports to The City’s consulting team for review. Any resulting impact or modifications required to the original design during construction shall be approved by the Professional Engineer(s) of Record and incorporated on submitted as-built and/or record drawings.
- .3 Delegated design of primary gravity and lateral load resisting system as well as ice-slab is not permitted unless otherwise requested by the business unit or civic partner during the initial scope discussions with structural consultant.

## 6.9 Parking Areas

- .1 Parking structures, and areas used for parking and vehicular access within, under or on buildings containing other occupancies, to be designed to CSA-S413 Parking Structures.
- .2 Penetrating concrete sealers referred to in CSA-S413 clause A2.3 to be restricted to the Approved Product List for Sealers Used on Concrete Bridge Elements, latest edition, by Alberta Transportation.
- .3 For concrete reinforcement close to chloride-exposed surfaces such as corrosive environments and areas subject to de-icing salts, refer to Materials section 8.6.
- .4 Required concrete permeability index prequalification tests to utilize ASTM C1202.
- .5 The suggested establishment of contractor procedures for quality assurance per CSA-S413 Annex D.1.3, and responsibilities of designer, protection system specifier, prime consultant, contractor and owner per CSA-S413 Annex F, are to be formalized in the design specifications.
- .6 Provide a draft copy of the Owner’s Maintenance Program to The City for review and comment.
- .7 If considering the use of High Performance Concrete (HPC), meet the design recommendations for HPC contained in Guidelines for Bridges & Structures by The City’s Transportation Infrastructure - Bridges and Structures division.



- .8 Exterior parking structures:
  - .1 Design for “sun-camber” reversing moments and expansion in the top level.
  - .2 Consider loading criteria for snow removal vehicles, snow stockpiles landscaping and planters.
- .9 Design detailing:
  - .1 In pre-stressed components, provide a minimum 1.4 MPa pre-stress with zero tension at service loads.
  - .2 Maintain positive floor camber after final loading and creep.
  - .3 Consider a thick membrane, fire sprinkler and ventilation systems and curb loads for areas accessible to trucks (e.g., garbage, fire) and buses.
  - .4 Minimize column and wall sizes to limit restraint cracking.
  - .5 Do not fix bottom of tee-sections at both ends.
  - .6 Do not finalize connections of pre-cast members within 28 days of fabrication.
  - .7 Provide additional crack reinforcement at dapped beam ends.
  - .8 Top slab reinforcement to be minimum 15M bars.
  - .9 Connections to be accessible for inspection and maintenance (e.g., at flange soffits) and corrosion-resistant.
  - .10 Provide gap between weld plate edges and concrete to allow for welding expansion.
  - .11 Do not locate expansion joints at cantilevers or at wheel-turning areas.
  - .12 Contraction joints to be tooled-in or saw-cut not routed. Lightly grind saw-cuts to find loosened concrete. Fill with polyurethane sealant.
  - .13 Non-structural building components in the splash zone near floor level to be corrosion-resistant.
  - .14 Avoid inflexible block walls on long-span components.
  - .15 Avoid shared drain openings between pre-cast components.
  - .16 Guards:
    - a. Gap or slip-joint one end between columns.
    - b. Slip-joint between every second post at curves.
    - c. Posts pocket grout to be proud and crowned.
    - d. Caulk around any un-galvanized posts.

## 6.10 Detailing

- .1 Guardrails (including anchorages) located in areas of possible vehicle impact shall be designed for collision loads and ease of repair such as with modular construction, replaceable anchorage connections, and easy replacement of only the damaged components.
- .2 Locate bollards adjacent exterior major structural components such as load bearing walls, columns and stairs adjacent roadways, laneways and vehicle drive aisles. Consider the use of flexible bollards adjacent non-critical components adjacent vehicle drive aisles.
- .3 Locate concrete control joints in reglets or other architectural details.

- .4 Concrete formwork ties should be arranged in a regular pattern and sealed with a non-shrink type grout including water proofing properties where required.
- .5 Concrete reinforcement within 100 mm of surfaces exposed to rain, chlorides or other de-icing chemicals shall be galvanized Grade 400W reinforcing steel bars. The Professional Engineer of Record may consider non-corroding materials such as stainless steel or FRP where deemed appropriate.
- .6 Where a slab on grade will be constructed over a significant depth of backfill, replacement or engineered fill (>1 m), and the site is not pre-loaded, design the slab on grade to bridge over the backfill where slab joints or mid-slab movements are not tolerable for long term durability of the slab. Coordinate the support/suspension of all applicable service piping to accommodate the expected movement.
- .7 Increased concrete cover to reinforcement, in accordance with CSA S6 should be specified for all components in exposed and/or corrosive environments.
- .8 Concrete slab on grade jointing shall consider the following:
  - .1 Concrete slab-on-grade transverse and longitudinal shrinkage control joints shall be spaced closer together where tied into previously-cast or non-shrinking components.
  - .2 Also consider moist-curing a concrete slab for a minimum of 7 days where crack widths may be a concern. Saw-cutting of the slab should occur within 18 hours of placement.
  - .3 Coordinate concrete slab joints with floor finish joints and allow for shrinkage movements within the finish joints.
  - .4 Provide shrinkage control joint at concrete slab edge thickenings.
  - .5 A horizontal-smooth-dowel method of creating a horizontal slip joint is discouraged. Inevitable variations off horizontal and perpendicular will negate movement. Instead utilize a plate-dowel or diamond-dowel system.
  - .6 Concrete slab control joint depth is to be a maximum of 1/3 of the slab thickness. Ensure the specified reinforcement depth is coordinated with the specified control joints.
  - .7 Where floor slabs are not tied into the supporting structure such as walls and columns, coordinate expected horizontal shrinkage and relative vertical movement of the structure with the specified interior finishes.
- .9 Above pool areas, specify corrosion-resistant paint to top of open web steel joists and steel beams against roof decking, and metal deck fasteners instead of puddle welds.
- .10 Design floor expansion joints to permit unencumbered and smooth wheeled travel.
- .11 Design expansion joints in roofs, walls and/or floors to allow vertical, horizontal and rotation movements expected due to relative movement between buildings. These movements shall include effects due to settlement, wind, temperature and storey drift.
- .12 Slope structure to match the major roof drainage slopes, where possible.
- .13 Design the roof structure to minimize snow and ice melt directly from roof to vehicle and pedestrian traffic below. Divert run off to drains at adjacent buildings where possible.
- .14 Consider structure shape and orientation to control ice build-up, melt runoff and sliding snow hazards by minimizing or re-orientating roof slopes, incorporating curbs, ice melt systems or snow guards.

- .15 For all HSS and pipe members subject to exposure and/or freezing:
  - .1 Provide drain holes at lowest point.
  - .2 Provide seals (e.g., neoprene) around all fastening penetrations exposed to water.
  - .3 Provide positive drainage at the base of the column.
  - .4 Provide cap plates at columns ends.
- .16 Provide drain holes in galvanized components, to facilitate proper galvanization and drainage of condensation moisture.
- .17 For weld plates embedded in concrete, leave either zero or sufficient edge distance so that plate thermal expansion under welding will not spall concrete.
- .18 Where long-span members are parallel to stiff elements (e.g., walls or shorter spans), limit the allowable relative deflection under total load (e.g., deck topping or roofing plus live or environmental loads) to avoid distress to the floor and/or roof framing.
- .19 All new and renovated elevated walkways shall incorporate a minimum soffit depth. The minimum dimension between the underside of structure and soffit shall be 300 mm.
- .20 All major structural components and/or connections including but not limited to expansion joints, roof structure, floor structure, etc. on the adjacent building supports, shall be accessible for periodic inspection, repair and/or maintenance. Access panels shall be easily removable.

## 6.11 Construction Inspection and Testing Agencies

- .1 Design documents are to note that The City (not Contractor) will engage construction inspection and testing agencies for quality assurance including but not limited to:
  - .1 Professional geotechnical inspection of allowable bearing pressure for all footings, and inspection of soil anchors, MSE walls etc.
  - .2 Pre-construction surveys and vibration monitoring of adjacent properties as per geotechnical recommendations.
  - .3 Pile inspections.
  - .4 Soil compactions.
  - .5 Concrete mix design review, and concrete sampling.
  - .6 Structural steel inspections including confirmation of welding certificates, a minimum visual inspection of 100% and a minimum ultrasonic inspection of 10% of site and shop structural welds, and visual inspection of 20% of metal deck connections.
  - .7 Structural steel inspections including visual inspections of all snug-tightened, high-strength bolted connections, surface preparations and cleaning for painted and galvanized steel, and a minimum on one inspection to verify the paint, primer, coating and galvanizing thicknesses.
- .2 The scale of project shall dictate type and scale of inspections and testing required.
- .3 The Contractor is to remain responsible for all quality control inspection and testing.
- .4 The Professional Engineer of Record is responsible to review all inspections and testing and fulfill professional obligations of conducting site reviews to verify construction compliance and perform due diligence.

## 6.12 Antenna-supporting Towers and Structures

- .1 These requirements apply to Site Licensees (leases) and to City-operated antenna supports on City-owned land and facilities.
- .2 Antenna supports extending 15m or more above adjacent grade or roof, CSA Standard S37 Antennas, Towers, and Antenna-Supporting Structures shall apply in its entirety.
- .3 Unless confirmed otherwise in writing by The City, the Importance Factor for loading design and evaluation is to be considered Normal.
- .4 Specify provision of warning signage on any existing or new support not having climbing and safety devices compliant with the current Standard.
- .5 Design of foundations or supporting structure for the Antenna shall be completed by a Professional Engineer registered in the Province of Alberta. It is the responsibility of the design engineer to confirm the adequacy of any existing building or structure to support the antenna and review the installation of the support.
- .6 Any existing tower modifications or antenna changes must be reviewed by a Professional Engineer to confirm the adequacy of the foundation and structure to support the revised configuration.

## 6.13 Acoustics and Vibration

- .1 Refer to Section 9 – Acoustics and Vibration.





## Section 7 – Mechanical

<b>7.1</b>	<b>Codes and Standards</b> .....	<b>36</b>
<b>7.2</b>	<b>General Mechanical Design</b> .....	<b>37</b>
<b>7.3</b>	<b>Design Criteria</b> .....	<b>38</b>
<b>7.4</b>	<b>Plumbing and Drainage</b> .....	<b>39</b>
<b>7.5</b>	<b>Fire Protection</b> .....	<b>41</b>
<b>7.6</b>	<b>Heating</b> .....	<b>43</b>
<b>7.7</b>	<b>Cooling</b> .....	<b>45</b>
<b>7.8</b>	<b>Supply Air Handling</b> .....	<b>46</b>
<b>7.9</b>	<b>Electric Motors</b> .....	<b>48</b>
<b>7.10</b>	<b>Variable Frequency Drives (VFDs)</b> .....	<b>48</b>
<b>7.11</b>	<b>Geoexchange Systems</b> .....	<b>48</b>
<b>7.12</b>	<b>Refrigeration Rooms</b> .....	<b>49</b>
<b>7.13</b>	<b>Equipment, Pipe, and Ductwork Identification</b> .....	<b>49</b>
<b>7.14</b>	<b>Controls</b> .....	<b>50</b>
<b>7.15</b>	<b>Start-up and Testing</b> .....	<b>52</b>
<b>7.16</b>	<b>Acoustics and Vibration</b> .....	<b>53</b>

## 7.1 Codes and Standards

- .1 In addition to the documents listed in Section 1.4, new design, additions, upgrades and repairs to conform to or exceed the latest edition of the following codes and standards generally, plus those specifically referenced in following clauses:
  - .1 National Fire Protection Association (NFPA) including:
    - a. NFPA 10 – Portable Fire Extinguishers.
    - b. NFPA 13 – Installation of Sprinkler Systems.
    - c. NFPA 14 – Installation of Standpipe and Hose System.
    - d. NFPA 20 – Standard for the Installation of Stationary Pumps for Fire Protection.
    - e. NFPA 25 – Standard for the Inspection, Testing, and Maintenance of Water-Based Fire Protection Systems.
    - f. NFPA 72 – National Fire Alarm and Signaling Code.
    - g. NFPA 90A – Installation of Air Conditioning and Ventilation Systems.
    - h. NFPA 96 – Ventilation Control and Fire Protection of Commercial Cooking Operations.
    - i. NFPA 2001– Standard on Clean Agent Fire Extinguishing System.
  - .2 Canadian Standards Association including:
    - a. CAN/CSA-B52 – Mechanical Refrigeration Code.
    - b. CAN/CSA-B125.1, B125.3 – Plumbing Supply Fittings, Plumbing Fittings.
    - c. CAN/CSA-B139 – Installation Code for Oil Burning Equipment.
    - d. CAN/CSA-B149.1 – Natural Gas and Propane Installation Code.
    - e. CAN/CSA-B149.2 – Propane Storage and Handling Code.
    - f. CAN/CSA- 448 – Design and Installation of Earth Energy Systems.
  - .3 Underwriters Laboratories of Canada.
  - .4 Alberta Occupational Health and Safety Act:
    - a. Ventilation Regulation.
    - b. Noise Regulation.
  - .5 American Society of Heating, Refrigeration, and Air-Conditioning Engineers (ASHRAE) Standards including:
    - a. ASHRAE 52.2 - Method of Testing General Ventilation Air-Cleaning Devices for Removal Efficiency by Particle Size.
    - b. ASHRAE 55 - Thermal Environmental Conditions for Human Occupancy.
    - c. ASHRAE 62.1 - Ventilation for Acceptable Indoor Air Quality.
    - d. ASHRAE 90.1 - Energy Standard for Buildings except Low Rise Residential Buildings.
    - e. ASHRAE 129 - Measuring Air Change Effectiveness.
    - f. ASHRAE Handbooks.

- .6 Industrial Ventilation: A Manual of Recommended Practice, American Conference of Governmental Industrial Hygienists.
- .7 Sheet Metal and Air Conditioning Contractors Association (SMACNA) Standards.
- .8 ASTM B88 – Standard Specifications for Seamless Copper Water Tube.
- .9 ASTM B306 – Standard Specification for Copper Drainage Tube (DWV).
- .10 CAN/CSA-B70-12 Cast iron soil pipe, fittings, and means of joining.

## 7.2 General Mechanical Design

At the preliminary design stage, the consultant to provide the client business unit or civic partner Project Manager a schematic design brief as outlined in the Design Guidelines for City of Calgary Funded Buildings – Volume 2 – Consultant Scope and Deliverables Manual.

- .1 Detailed procedures to be followed by consultants:
  - .1 For small projects sketches to be provided showing:
    - a. The locations where the pipe and duct mains will be run.
    - b. Ventilation and air distribution strategy.
    - c. Heating / cooling equipment.
    - d. Space temperature control strategy.
    - e. Equipment locations.
  - .2 Heating/cooling load calculations and any other relevant design data including energy simulations to be submitted at the request of the client business unit or civic partner project manager for any new building construction, major renovations and retrofits.
  - .3 A zone by zone ventilation rate calculation summary is to be provided based on the procedure detailed in ASHRAE 62. The data is to be provided in tabular format and included on the mechanical drawings. The table is to contain at minimum the following information for each zone: zone area ( $A_z$ ), zone population ( $P_z$ ), outside air rate per area ( $R_p$ ), outside air rate per person ( $R_s$ ), outside air required ( $V_{bz}$ ), and outside air supplied ( $V_{sup}$ ).
- .2 Energy:
  - .1 The building design, equipment, and systems shall conform to, as a minimum, the currently enforced version of NECB and the mandatory provisions of the most current version of ASHRAE 90.1.
- .3 Metering:
  - .1 The City of Calgary Corporate Engineering is to be consulted on the appropriate level of natural gas utility metering, and any energy usage metering that may be required for each project. Sub-metering of natural gas utilities to various buildings or equipment shall be evaluated on a project to project basis.
  - .2 The City of Calgary Water Resources to be consulted on appropriate level of water utility metering that may be required for each project.

- .4 Accessibility to Equipment:
  - .1 Provide sufficient access space for servicing, maintaining and removal of equipment and components (coils, exchangers, fans, motors, filters, etc.).
  - .2 Indicate access space required for equipment maintenance on drawings.
  - .3 Coordinate with Architect to provide access doors to concealed mechanical equipment for servicing access. Locate and size access doors such that all concealed items are accessible and so that body or hand entry (as required) is achieved.
  - .4 Provide hoist lift points.
- .5 Hazardous Materials:
  - .1 Be aware of possible asbestos materials and surfaces and follow regulatory requirements. Refer to Section 10 of this guideline.

## 7.3 Design Criteria

- .1 Design mechanical systems for typical office occupancies based on criteria set out below. Special buildings or areas within buildings may require different conditions than those outlined. Document these conditions and make allowances in the system design.
- .2 Base heating design on outdoor ambient temperatures given in the National Building Code, Alberta Edition. For Calgary the 2.5% January Outdoor Design Temperature is -30°C.
- .3 Base cooling design on outdoor ambient temperatures given in the National Building Code, Alberta Edition. For Calgary the 2.5% July Outdoor Design Temperature is 28°C dry bulb, 17°C wet bulb.
- .4 Minimum indoor environmental design requirements:
  - .1 Indoor temperature (heating): 22°C.
  - .2 Indoor temperature (cooling): 25°C.
  - .3 Electrical rooms shall be maintained to maximum temperature of 25°C at all times.
  - .4 In general, heating and air conditioning systems are to be capable of meeting the requirements of ASHRAE Standard 55.
  - .5 Overall Ventilation Rate: as per ASHRAE Standard 62.1 (Relevant Version as noted in ABC or as approved by The City of Calgary). Consider using demand controlled ventilation via space CO2 sensors where practical.
  - .6 Humidification; When required humidification is to range from 15%RH when outdoor air temperatures are -30°C or less, to 40%RH when outdoor temperatures are 20°C or more. Some areas or building types (museums, document storage, and computer rooms) may have more specific humidity requirements or require precision control of humidity set point. Confirm with client business unit or civic partner.
- .5 For all other occupancies discuss these parameters in early design phases to ensure design considerations will meet the expectations of the City BU and maintenance staff.

## 7.4 Plumbing and Drainage

- .1 Domestic Water Service:
  - .1 Domestic water heaters should not serve building heating systems. However, it is acceptable to use base building heating systems to heat domestic hot water indirectly.
  - .2 Provide domestic hot water re-circulating piping complete with balancing valves where hot water supply length exceeds 15m.
  - .3 Provide backflow prevention that conforms to either The National Plumbing Code of Canada or the requirements of The City of Calgary, whichever is more stringent.
  - .4 Domestic water piping to be type L copper to ASTM B88. Solder for fittings to be lead-free. Grooved fittings not permitted on domestic water piping.
  - .5 Domestic hot water recirculation lines to be type K copper to ASTM B88 and installed with long radius elbows.
  - .6 Consider solar water heating technologies.
  - .7 Hose bibs if required are to be non-freeze key operated type complete with isolating valves. Provide hose bibs at a minimum of every 30m around the building perimeter.
  - .8 Consider instantaneous water heaters as appropriate for the application.
  - .9 Specify water softeners for all steam humidifiers and instantaneous hot water heaters.
- .2 Sanitary Sewer Piping System:
  - .1 All below slab sanitary piping to be minimum 50 mm Dia.
  - .2 Sanitary drains and vents 65 mm and larger shall be cast iron to CAN/CSA-B70-12.
  - .3 Sanitary drains and vents 50 mm and smaller shall be hard temper DWV copper drainage piping to ASTM B306.
  - .4 Provide floor drains in all washrooms that contain more than one water closet or any urinals.
  - .5 Install trap primers as required by National Plumbing Code. Ensure locations of trap primers are shown on drawings, coordinated with Architectural and Electrical Divisions, and accessible for future service.
  - .6 Provide heat tracing and insulation of sanitary piping where it is at risk of freezing.
  - .7 Provide interceptors where required by code.
  - .8 Provide the necessary double compartment sumps as required to suit occupancy and use.



- .3 Storm Drainage System:
  - .1 Provide a minimum of two roof drains per contained near-flat roof area, except a single drain may be provided for near flat roof areas not greater than 6 sq. meters, i.e. entrance canopies, elevator penthouses.
  - .2 If possible, avoid use of control flow drains. If installed, ensure Structural consultant allows for this load and building envelope is designed for water storage on roof.
  - .3 Consider 100 mm as minimum size of roof drains to help prevent plugging with debris over time.
  - .4 If possible, route storm drainage internally within the building and connect directly to the City storm sewer system. Avoid discharging flow to grade.
  - .5 Insulate roof drain sumps and horizontal storm piping with minimum 12 mm preformed glass fibre pipe insulation c/w vapour barrier.
  - .6 Storm drainage piping shall be cast iron to CAN/CSA-B70-12.
  - .7 Provide heat tracing and insulation of storm piping where it is at risk of freezing.
  - .8 If discharging storm water to grade, do not allow flow onto pedestrian or vehicle traffic areas where it could freeze and become a safety hazard or onto areas where it could cause erosion damage.
  - .9 Explore storm water harvesting opportunities and incorporate if practical and Triple Bottom Line goals are satisfied.
- .4 Plumbing Fixtures:
  - .1 All new plumbing fixtures to adhere to the City of Calgary Water Utility Bylaw 40M2006 as a minimum performance requirement.
  - .2 All new plumbing fixtures to be CSA approved.
  - .3 All plumbing fixtures in non-residential buildings to be commercial grade.
  - .4 Where hands-free electronically actuated fixtures are specified, consider specifying hard wired fixtures in lieu of battery powered fixtures.
  - .5 Waterless urinals will not be accepted.
- .5 Natural Gas Service:
  - .1 Natural gas piping shall be to be in accordance with ASTM A53, Schedule 40. Weld all distribution piping within the building and utilize screwed and/or flanged fittings at equipment only.

## 7.5 Fire Protection

### .1 General:

#### .1 Sprinkler Design Requirements:

- a. Where sprinkler system is to be installed, system shall be designed and installed as per NFPA 13.
- b. Conduct flow and pressure test of water supply in vicinity of project to obtain criteria for bases of design in accordance with NFPA 13.
- c. In area subject to freezing, install a dry-pipe system.
- d. Discharge from individual heads in hydraulically most remote area to be 100% of specified density.
- e. Consultant shall provide hydraulic calculations in accordance with the requirements of NFPA 13, showing that the pipe sizes provided will produce adequate performance.
- f. A minimum safety factor of 10 psi or 10%, whichever is greater, of the available pressure at the required system flow (including all required hose stream demands) shall be demonstrated in the hydraulic calculations.
- g. All sprinkler heads located in storage rooms, electrical rooms or rooms where there is a risk of potential damage are to be equipped with guards to provide protection against accidental damage.
- h. Install shields where necessary to protect electrical equipment from sprinkler discharge. Shields shall be such that water spray from sprinklers is shielded from the intended equipment only. Shields shall not completely block water spray over the remainder of the area to be protected. Coordinate with electrical drawings for these locations.

#### .2 Pipe, Fittings and Valves:

- a. All sprinklers, pipes, fittings, hangers, valves, and other materials and equipment shall be ULC Listed for their intended use.
- b. Sprinkler piping to be black steel, Schedule 40 and meet the requirements of ASTM A53.
- c. Grooved fitting systems are acceptable on piping 65 mm and larger. All piping 50 mm and smaller to be screwed.
- d. Dry pipe and fittings shall be galvanized.
- e. Ensure fittings, mechanical couplings, and rubber gaskets are supplied by the same manufacturer.
- f. Provide pipe sleeves where piping passes through walls, floors, and roofs.
- g. In fire walls and fire floors, seal both ends of pipe sleeves or core-drilled holes with ULC listed fill, void, or cavity material.

#### .3 Submittals and Product Data:

- a. Provide manufacturer's printed product literature and data sheets, and include product characteristics, performance criteria, physical size, finish and limitations.

- .4 Shop Drawings:
  - a. Submit drawings stamped and signed by a Professional Engineer registered or licensed in Alberta, Canada.
  - b. Indicate:
    - Materials.
    - Finishes.
    - Method of anchorage.
    - Number of anchors.
    - Supports.
    - Reinforcement.
    - Assembly details.
    - Accessories.
    - Layout of sprinkler heads and associated piping.
- .5 Test Report:
  - a. Submit certified test reports for wet/dry pipe fire protection sprinkler systems from approved independent testing laboratories, indicating compliance with specifications for specified performance characteristics and physical properties.
- .6 Certificates:
  - a. Submit certificates signed by manufacturer certifying that materials comply with specified performance characteristics and physical properties.
  - b. Submit Alberta Building Code schedules A, B and C for sprinkler system signed and sealed by a Professional Engineer registered in Alberta.
- .7 Fire Extinguishers:
  - a. Portable fire extinguishers shall be installed, maintained and tested in accordance with NFPA 10.
  - b. Clean agent fire extinguishing systems shall comply with NFPA 2001.
- .8 Standpipe and Hose System:
  - a. Design of standpipe and hose system shall comply with NFPA 14.
- .9 Notice to Fire Department:
  - a. Existing fire protection system(s) shall not be taken out of service without prior written approval from the Owner's Representative, and notification to the Calgary Fire Department. If such systems are taken out of service, the Consultant/Contractor shall provide fire watch acceptable to the Owner and the Authority Having Jurisdiction, until those systems are replaced or restored to service.

.10 Field Quality Control for Sprinkler System:

a. Site Test, Inspection:

- Perform test to determine compliance with specified requirements.
- Test, inspect, and approve piping before covering or concealing.

b. Preliminary Tests:

- Hydrostatically test each system at 200 psig for a 2 hour period with no leakage or reduction in pressure.
- Flush piping with potable water in accordance with NFPA 13.
- Piping above suspended ceilings: tested, inspected, and approved before installation of ceilings.
- Test alarms and other devices.
- Test water flow alarms by flowing water through inspector's test connection. When tests have been completed and corrections made, submit signed and dated certificate in accordance with NFPA 13.

c. Formal Tests and Inspections:

- Do not submit request for formal test and inspection until preliminary test and corrections are completed and approved.
- Submit written request for formal inspection at least 15 days prior to inspection date.
- Repeat required tests as directed.
- Correct defects and make additional tests until systems comply with contract requirements.
- AHJ will witness formal tests and approve systems before they are accepted.

## 7.6 Heating

.1 Heating Plant:

Provide boiler plant that allows for redundancy and extra capacity for pickup losses (if applicable) as well as future expansion. Typically, two boilers, each sized to 60%-75% of total heating design capacity satisfies this requirement. Provide control sequence for alternating the lead boiler to equalize the running hours between all boilers.

- .1 Utilizing alternative boiler setup and/or other heat sources is acceptable provided the proposed heating strategy is reviewed and approved by the client business unit or civic partner.
- .2 Establish capacities, arrangement, and number of boilers such that when any one boiler is out of service, the remaining boilers shall be sufficient to offset building transmission heat loss. Note that this may exclude heat for ventilation.
- .3 Boilers to have fully modulating burner controls with high turn-down ratios.
- .4 Consider installing condensing boilers as appropriate. Where condensing boilers are used, ensure acid neutralization is provided on condensate drain from boiler and the supply/return loop temperatures are designed to maximize operation in the condensing mode.

- .5 Boilers shall incorporate means for preventing heat losses through the boilers when they are not in operation, such as 3-way bypass valves or check valves that prevent the flow of heat carrying fluid through boilers that are not operating.
  - .6 Provide a minimum of two primary circulation pumps, sized for parallel pump operation.
  - .7 In general, pumping systems should be designed for variable flow. The use of three-way control valves and bypass for modulating flow to equipment should be avoided.
  - .8 Chemical treatment equipment shall be located to facilitate access for maintenance. Chemical pot feeders and filter housings shall be less than 1000 mm and 1500 mm above finished floor respectively.
  - .9 Provide contacts for Building Management System (BMS) control system (if building is BMS controlled) including boiler enable, burner firing rate, and flame failure alarm.
  - .10 In large mechanical rooms containing boilers and/or natural gas burning equipment, provide ventilation to control the room temperature within the temperature ratings of the equipment. Provide adequate outside air for combustion and ensure proper venting of flue gases.
- .2 Heating Distribution:
- .1 Provide a separate glycol loop for the air handling system coils, separate from water loop supplying fin tube radiation, radiant panels, and terminal reheat coils.
  - .2 Provide 50% glycol solution for heating coils in air handling units. Ensure pre-mixed glycol is specified.
  - .3 Two pipe reverse return system preferred for heating water piping.
  - .4 Grooved fittings are not permitted on heating water piping.
  - .5 Pipes 65 mm to 250 mm to be in accordance with ASTM A53, Schedule 40. Pipes 50 mm and smaller to ASTM A53, Schedule 40 or hard-tempered copper to ASTM B88, Type L.
  - .6 Include provisions for water treatment. Coordinate with client facility operation manager on specific needs for water treatment.
  - .7 Show all required expansion joints, expansion loops, pipe guides, and pipe anchors with estimated loads on drawings.
  - .8 Provide isolation valves and circuit balancing valves as required on supply and return mains, risers and any major branches.
- .3 Heating Terminal Units:
- .1 Where perimeter radiation and reheat coil serve the same space, radiation to operate initially and in sequence to reheat coil.
  - .2 Each perimeter fin radiation zone to have isolating valves and control valves on supply side. On return side install balancing valve and isolating valve. Install air vents on high side of return. Provide access to all valves and accessories associated with the terminals.
  - .3 Provide means of isolation, balancing and flow measurement for equipment and major loop circuits.
  - .4 Pipe run outs to terminal units to be soft-temper Type L copper, to ASTM B88.



## 7.7 Cooling

- .1 General:
  - .1 Cooling system guidelines:
    - a. Direct expansion refrigeration recommended when the cooling load is 80 tons or less. Provide hot gas bypass control on first compressor.
    - b. Consider air cooled chiller or evaporative cooling tower when cooling load is 80 tons and above. KW/ton and EER ratings of various cooling equipment options to be evaluated when making a decision on system selected.
    - c. Once through cooling systems shall not be used.
  - .2 Provide chillers that allow supply water to be reset electronically.
  - .3 Consider variable flow pumping to conserve energy use.
  - .4 Include provisions for water treatment.
  - .5 Air and water side economizer strategies are to be employed where possible.
- .2 Sizing: Air Conditioning equipment to be sized based on the calculated block cooling load requirements and diversity. Do not apply any safety factor when sizing cooling equipment.
- .3 Refrigeration Equipment: Design refrigeration systems in conformance with CSA/CAN-B52 Mechanical Refrigeration Code.
  - .1 Use only non-ozone-depleting refrigerants. Chlorofluorocarbon (CFC)-based refrigerants are not acceptable. Select refrigerants to minimize or eliminate the emission of compounds that contribute to ozone depletion and climate change.
  - .2 When reusing existing equipment in an upgrade or renovation, discuss a CFC-based refrigerant phase-out plan as part of the project scope.
  - .3 Compressors to have minimum 5 year warranty.
- .4 Cooling Distribution:
  - .1 Two pipe reverse return system preferred for cooling water piping.
    - a. Grooved fittings are not permitted for cooling water piping.
    - b. Pipes 65 mm to 250 mm to be in accordance with ASTM A53, Schedule 40. Pipes 50 mm and smaller to ASTM A53, Schedule 40 or hard-tempered copper to ASTM B88, Type L.
    - c. Pipe runouts to terminal units to be soft-temper Type L copper, to ASTM B88.
    - d. Provide means of isolation, balancing and flow measurement for equipment and major loop circuits. Provide access to all valves and accessories associated with the terminals.
    - e. Provide isolation valves and circuit balancing valves as required on supply and return mains, risers and any major branches.

## 7.8 Supply Air Handling

- .1 General
  - .1 Consider designing HVAC system to decouple ventilation loads from heating and cooling loads (e.g., Dedicated Outdoor Air System (DOAS), etc.).
- .2 Air Handling Equipment:
  - .1 Air handling system to be complete with economizer cycle including 100% outside air for cooling if applicable.
  - .2 Provide air plenums with hinged, sealed access doors and lighting for inspection of each chamber. Access doors to be complete with lockable lever handles operable from both sides.
  - .3 As a minimum provide air filters with minimum dust spot efficiency of 30% (MERV 8) based on ASHRAE 52.1. For hydronic systems provide summer/winter position filters. Consider MERV 13 filtration depending on the occupancy and /or if designated as an owner priority.
  - .4 Do not utilize mechanical rooms as air plenums.
  - .5 Custom equipment, except 100% dedicated outdoor air units and residential style furnaces, in excess of 1000 L/S shall be specified with a return fan. Where buildings use multiple smaller packaged rooftop units, it is recommended to use general exhaust fans or power exhaust in order to control building pressurization. Locate packaged units with power exhaust over unoccupied or sound non-critical areas to avoid noise transfer to occupied areas.
  - .6 Cabinet panels to be: 18 gauge for air handlers supplying less than 10,000 L/S; 16 gauge for air handlers supplying more than 10,000 L/S.
  - .7 Cabinet floor panels to be 16 gauge. Floor panels next to potentially wet areas to be non-slip.
  - .8 Panels to be complete with 50 mm thick insulation.
  - .9 Provide energy recovery ventilation equipment as required by NECB. This equipment to be monitored by building automation system.
  - .10 Refrigerant coils with multiple compressors shall be alternate tube circuited in order to distribute the cooling effect over the entire coil face at reduced load conditions.
  - .11 Bearings to be anti-friction ball, roller, and self-aligning pillow block type bearings with heavy clamp lock as opposed to set screws. Bearings are to be selected for minimum L10 bearing life of 40,000 hours when operating at maximum catalogued class conditions. Consider L10 bearing life of 200,000 hours for critical and 24/7 applications.
  - .12 Fan shafts: solid AISI C-1040 or 1045 hot rolled steel accurately turned ground and polished, and ring gauged for accuracy. All shafts must be dial indicated for straightness after the keyways are cut and straightened as required. Shafts shall be sized for first critical speeds at least 1.43 times the maximum speeds of the fan.
  - .13 Fan wheels: blades shall be true lined, statically and dynamically balanced on precision electronic balancers. Each fan assembly shall be designed for critical speeds of at least 1.35 times the maximum speed of the fan.
  - .14 DX coil section, filter section, mixing section, heating coil section shall be provided with 22 gauge solid galvanized steel liner over insulated areas.
  - .15 Fan section to have 24 gauge perforated galvanized steel liner over insulated areas.

- .16 For outdoor and exhaust air dampers utilize aluminum thermally insulated dampers with leakage characteristics of 25 L/s/m<sup>2</sup> at 1 KPa differential static pressure at -40°C. For return air dampers utilize non-insulated aluminum airfoil dampers with leakage characteristics of 52 L/s/m<sup>2</sup> at 1 KPa differential static pressure at -40°C.
- .17 Disconnect switch enclosure for outdoor units shall be NEMA 4.
- .18 Extended grease lines to be primed with grease at the factory.
- .19 Provide 25 mm bird screen mesh for air openings at the air handling unit.
- .20 Power cable within the air handling unit serving fan motors to be liquid tight.
- .21 Units shall be produced by a recognized manufacturer, who has complete catalogue information and who maintains a local service agency with factory trained mechanics and parts stock.
- .3 Natural Ventilation: Consider natural ventilation strategies as deemed applicable and practical.
- .4 Zoning: Zone air systems based on space usage, occupied hours, and exterior exposures. Match areas to appropriate heating and cooling zones. Provide separate zones for corner exposures.
- .5 Distribution:
  - .1 Ductwork to be fabricated from galvanized or stainless steel to SMACNA standards.
  - .2 Ensure that proper air distribution is achieved through correct diffuser application, selection, and location in the ceiling grid.
  - .3 Take into account variable air volumes and tenant requirements so that adequate air circulation is achieved under all conditions.
- .6 Variable Air Volume (VAV):
  - .1 On VAV systems use variable frequency drives on fan motors to modulate supply and return air volumes.
  - .2 Ensure selected fan curve has a stable region that covers the entire operating speed range.
  - .3 Sequence heating elements (perimeter fin tube radiation or reheat coils) and VAV boxes on the same temperature space sensor.
  - .4 Drawing schedule to provide minimum and maximum air volumes for boxes.
- 7 Rooftop Units:
  - .1 If at all possible, air handling units to be installed in interior dedicated mechanical service rooms. Provide electrical convenience outlets on all rooftop units.
  - .2 Provide local electrical disconnect for each rooftop unit.
  - .3 Rooftop units to be installed on an insulated roof curb that has a minimum 350 mm height. For large units where an open structural frame support is required, provide a minimum of 1.0m clearance from the top of roof level to the underside of the equipment.
  - .4 Where possible provide large turndown natural gas valves for heating sections.
  - .5 Provide units with economizer function and incorporate return fan, general exhaust fans or power exhaust strategies in order to control building pressurization.

## 7.9 Electric Motors

- .1 Electric motors 1HP and larger shall be NEMA Premium efficiency rated.
- .2 Consider using ECM motors on all motors 1HP and smaller where possible.

## 7.10 Variable Frequency Drives (VFDs)

- .1 Ensure inverter duty motors are provided. Locate VFDs within 7 meters of the load.
- .2 Ensure VFDs are complete with:
  - .1 Line input reactor, DC line inductance or similar means to limit input total harmonic current distortion to less than 7% at the drive input.
  - .2 Electronic bypass consisting of a bypass contactor interlocked with a drive output contactor a drive input contactor, an overload relay and the associated logic circuitry mounted and wired in an auxiliary enclosure. An enclosure mounted drive/off/test switch is used to electrically select whether the motor is driven the line or disconnected from both. Input contactor to disconnect power automatically from the drive when in the "Off" and "Line" modes.
  - .3 24-month warranty.
  - .4 Fast acting one-time fuses on the drive line and slow acting time delay on the main line.
  - .5 A padlockable, door interlocked, two position rotary switch allows the input line to the drive to be disconnected.
  - .6 Serial communications protocol: BACnet / LONWorks / Siemens FLN communication protocols required.

## 7.11 Geexchange Systems

- .1 Geexchange systems are to be considered on a case by case basis. The proposed system is to be reviewed and approved by the client business unit or civic partner.
- .2 Engage specialist engineers as required with proven and successful performance in the geexchange industry to analyze the opportunities for geexchange implementation. The specialist must be accredited by the International Ground Source Heat Pump Association (IGSHPA).
- .3 The design, installation, equipment, materials, testing, verification and system start-up are to meet requirements of CSA Standard 448.
- .4 The ground loop heat exchanger (GLHE) must be designed and sized with ground loop sizing software using hourly heating and cooling loads from a detailed energy loads model created using approved energy modelling software. Rules of thumb are not an acceptable means of sizing the GLHE. The GLHE must be sized to perform over the life of the building, with no temperature degradation.
- .5 The site assessment and on-site testing is to be completed early in the design process. All projects shall have a minimum of one test borehole to determine in situ subsurface characteristics and thermal conductivity characteristics. Provide a copy of the Formation Thermal Conductivity Test Report.

- .6 The following documentation must be provided at minimum:
  - .1 Site Plan, indicating location of proposed borefield and all proposed and existing services.
  - .2 Borefield design, including number of boreholes, bore depth, bore spacing, piping type, fluid type, grout type and conductivity.
  - .3 Header details indicating pipe sizing, below grade piping connections and purging flow rates. Reducing header is to be included in detail.
  - .4 Manifold detail.
- .7 Methanol is not approved for use as a circulating fluid. The preference for circulating fluid is propylene glycol.
- .8 The system is to include sufficient instrumentation and monitoring points for ongoing performance monitoring and troubleshooting. At minimum, the following should be trended: GLHE field incoming and outgoing temperatures, heat pump loop temperatures, and pump speeds.
- .9 All design drawings are to be authenticated by an APEGA licensed engineer.

## 7.12 Refrigeration Rooms

- .1 Follow all requirements of CAN/CSA-B52 – Mechanical Refrigeration Code.
- .2 For extensive renovations of existing refrigeration rooms, it may be required to bring installation up to current version of code. Discuss with City of Calgary project manager early in the project to confirm.
- .3 Where damage could result at temperatures below freezing, ensure supplementary heating is provided to maintain a minimum machinery room temperature of 5°C at all times (including emergency ventilation condition following a refrigerant leak). For all new construction projects a dedicated make up air unit is required for this purpose. For retrofit projects where a dedicated make up air unit may not be feasible, alternate design solutions that meet this requirement can be reviewed on a case by case basis.

## 7.13 Equipment, Pipe, and Ductwork Identification

- .1 General
  - .1 All equipment, piping, ductwork, valves, and automation system components should be identified as follows as per this section.
  - .2 Provide flow direction arrows on piping and ductwork.
  - .3 Mark pipes and ductwork at each side of any wall, partition or floor, at 10 m intervals maximum on all exposed piping and ductwork and at each access panel or door. Marking shall be located so as to be in full view and visible from the floor.



- .2 Equipment Nameplates:
  - .1 Nameplates to have white letters on black backgrounds.
  - .2 Nameplates to be 3 mm thick laminated plastic with machine engraved lettering.
  - .3 Lettering size as follows:
    - a. Control panels/cabinets: 8 mm high lettering.
    - b. Equipment in mechanical rooms or outdoors: 20 mm high lettering.
    - c. All other equipment: 12 mm high lettering.
  - .4 Valve Tags:
    - a. All valves shall be tagged with brass valve tags.
    - b. Valve tags to be 40 mm diameter with 12 mm high lettering fastened to the valve via a brass chain.
    - c. Provide a valve tag directory, mounted in metal frame and protected with a clear acrylic sheet, indicating valve number, location, service, size, type of control, and normal operating position.
  - .5 Ductwork Identification:
    - a. Identify all ductwork with 50 mm high capitalized block letters stenciled in black or white paint to contrast with surface.
    - b. Identification to indicate whether ductwork is supply air (S/A), return air (R/A), outdoor air (O/A), or exhaust air (E/A).
  - .6 Piping Identification:
    - a. Conform to requirements of ANSI A13.1-2015.
    - b. All exposed piping to be identified.
    - c. Pipe identification to be done with pre-coiled vinyl pipe markers affixed with clear plastic tie-wraps.
    - d. Clearly identify any heat traced piping in addition to typical pipe identification.

## 7.14 Controls

- .1 Provide a complete system of automatic controls for HVAC equipment. If possible provide automated control for terminal unit devices in addition to the main central equipment.
- .2 All requirements of the Energy Management Control Systems (EMCS) to be provided by a single control contractor.
- .3 Systems to be based on Direct Digital Control /Stand Alone Controller (DDC/SAC) with electrical devices where specified.
- .4 The central DDC system shall monitor and control each system controller and any other miscellaneous mechanical equipment. Confirm with client BU or Civic partner whether the DDC system needs to be networked to allow for remote access. Coordinate with the electrical engineering design consultant to include in scope of work a data port in proximity of the panel in the event the EMCS will be networked either as part of the current project or in future.
- .5 Provide detailed control sequences for each mechanical system as well as any global optimization strategies. Include these sequences with construction documents.

- .6 EMCS to:
  - .1 Control heating, ventilating and air conditioning systems.
  - .2 Execute control strategies to minimize energy consumption.
  - .3 Monitor and record mechanical systems performance. Establish trending and logging requirements, data storage and export requirements to Corporate Engineering.
  - .4 Optimized start and stop times for systems or equipment that do not operate 24 hours a day.
  - .5 Coordinate with client business unit or civic partner on occupancy schedule.
  - .6 Deploy free cooling strategies as applicable.
  - .7 Deploy night and unoccupied set back strategies as applicable.
  - .8 Reset supply air, chilled water supply, and heating water supply temperatures via feedback from occupied spaces.
  - .9 Deploy demand control ventilation and occupancy control strategies as applicable.
  - .10 Minimize wear and tear on mechanical equipment and control system components.
- .7 Hardware:
  - .1 Control valves are not to be oversized and are to be selected with appropriate flow characteristics. Specify Cv for all control valves.
  - .2 Specify face area and pressure loss characteristic of modulating mixed dampers. Select damper, linkage type, and actuator power to provide linear volume control characteristic.
  - .3 Actuators to be electrically powered, except in retrofits where pneumatic power is available and still desired by the client business unit or civic partner.
- .8 Additional Requirements for Facility Management Managed Buildings:
  - .1 A Direct Digital Control (DDC) system will be provided for the building mechanical systems which will be able to connect and communicate with the Facility Operations, Siemens BMS Desigo CC Database Server without the use of any gateways or protocol converters.
  - .2 Control systems to be Client/Server based DDC System with capability of being controlled from a central station at the City of Calgary Facility Operations, EMCS Group work stations.
  - .3 Must be able to edit the Field Panel Program, Point Database, Trends, Alarm management, Scheduling and System Configuration from the Facility Operations, Siemens Desigo CC Database Server.
  - .4 All changes in programming and scheduling at the thick client to automatically update the remote field panel at the Shepard building.
  - .5 The Facility Operations, Siemens Desigo CC Database Server must be able to automatically backup or reload the entire field panel database in the event a field panel loses its database as the result of a cold start condition.
  - .6 BMS control systems that require manual database downloading at the field panel will not be permitted.
  - .7 Consultant to confirm any further requirements with Facility Management project manager and Corporate Engineering prior to detailed control system design.

## 7.15 Start-up and Testing

- .1 Include a complete list and test report forms for all tests required in the specification. Identify which test needs the consultant engineer to witness and those by the commissioning agent if applicable.
- .2 Contractor to conduct operating start-up to confirm that equipment and systems meet specified requirements after mechanical installations are completed and pressure tested and all systems are operational.
  - .1 Start-up of air systems:
    - a. Clean all new ductwork prior to start-up. Consider specifying duct cleaning of existing ductwork that is being re-used.
    - b. Start-up fans, coils circulators, humidifiers, exhaust air systems and interlocked cooling systems.
    - c. Balance in accordance to testing, adjusting, and balancing requirements.
  - .2 Start-up of hydronic systems:
    - a. Specify cleaning, flushing, and degreasing of all new hydronic piping.
    - b. Pressure test piping systems to 1-1/2 times the system working pressure but not less than 1035 kPa (150 psig). Systems shall be capable of holding test pressure over a period of 24 hours. Repair any leaks and re-test system if test is failed.
    - c. Start-up pumps, boilers, chillers, and all ancillary equipment.
    - d. Balance in accordance to testing, adjusting, and balancing requirements.
    - e. Check distribution system for fluid noise and pump noise.
  - .3 Start-up of plumbing systems
    - a. Pressure test plumbing systems as per requirements of National Plumbing Code.
    - b. Flushing and Cleaning: Flush entire system for 8 hrs. Ensure outlets flushed for 2 hrs. Let stand for 24hrs, then draw one sample off longest run. Submit to testing laboratory to verify system is clean. Let system flush for additional 2hrs, then draw another sample for testing.
    - c. Disinfection:
      - Supply materials and test kit to carry out disinfection as follows:
        - Fill piping system and tanks with chlorine/water solution with a strength of at least 50 mg/L. Ensure pipe is full and no air pockets remain.
        - Leave solution in piping system for 24 hours, while maintaining a pressure of 175 kPa.
        - After 24 hours sample and test the chlorine solution. If the chlorine residual is at least at 25 mg/L, the disinfection will be considered successful. Flush chlorine solution from the system. Protect against contamination of the disinfected system.
      - If the chlorine residual is less than 25mg/L, flush the system, clean any deleterious material, re-flush and disinfect again. Repeat until satisfactory.
      - If in the opinion of the mechanical consultant any component of the potable water system becomes contaminated after disinfection, it shall be flushed and disinfected again at no additional cost.

- Obtain water sample off longest run. Test in approved laboratory for bacteriological analysis and provide certification that all samples are suitable for human consumption prior to interim-occupancy inspection.
  - Upon completion provide laboratory test reports on water quality for mechanical consultant approval.
- d. Manufacturer Start-up: include for and coordinate manufacturer start-up of boilers, air handling units, chillers, cooling towers, and condensing units, water chemical treatment.
- .4 All tests forms required as per specifications to be recorded on the test report forms and submitted to the consultant.

## 7.16 Acoustics and Vibration

- .1 Refer to Section 9 - Acoustics and Vibration.



# Section 8 – Electrical

- 8.1 Codes and Standards ..... 55
- 8.2 General ..... 56
- 8.3 Site Electrical Services ..... 56
- 8.4 Service Distribution, Sub-Distribution and Panelboards ..... 57
- 8.5 Emergency Power Systems ..... 64
- 8.6 Conduit and Wiring ..... 64
- 8.7 Wiring Devices and Boxes ..... 65
- 8.8 Lighting ..... 65
- 8.9 Emergency and Exit Lights ..... 67
- 8.10 Fire Alarm System ..... 67
- 8.11 Security System ..... 67
- 8.12 Public Address System ..... 68
- 8.13 Telephone System ..... 68
- 8.14 Computer Network System ..... 68
- 8.15 In Building Cellular Communication Services ..... 68
- 8.16 Cable Television System ..... 68
- 8.17 Lightning Protection System ..... 68
- 8.18 Electrical Start-up and Testing ..... 69
- 8.19 Acoustics and Vibration ..... 69



## 8.1 Codes and Standards

- .1 In addition to the documents listed in Section 1.4, new design, additions, upgrades and repairs to conform to or exceed the latest edition of the following codes and standards generally:
  - .1 CSA C22.1 Canadian Electrical Code – Part 1.
  - .2 CAN/ULC Standards:
    - a. CAN/ULC-S524 Installation of Fire Alarm System.
    - b. CAN/ULC-S525: Audible Signal Devices for Fire Alarm Systems, Including Accessories.
    - c. CAN/ULC-S526: Visible Signal Devices for Fire Alarm System, Including Accessories.
    - d. CAN/ULC-S527: Standard for Control Units for Fire Alarm Systems.
    - e. CAN/ULC-S528: Manual Stations for Fire Alarm Systems, Including Accessories.
    - f. CAN/ULC-S529: Smoke Detectors for Fire Alarm Systems.
    - g. CAN/ULC-S530: Heat Actuated Fire Detectors for Fire Alarm Systems.
    - h. CAN/ULC-S531: Standard for Smoke-Alarms.
    - i. CAN/ULC-S536 Inspection and Testing of Fire Alarm Systems.
    - j. CAN/ULC-S537 Verification of Fire Alarm Systems.
    - k. CAN/ULC -S1001 Integrated Systems Testing of Fire Protection and Life Safety Systems.
  - .3 Canadian Standard Association:
    - a. CAN/CSA-B72-M87 Installation Code for Lightning Protection Systems.
    - b. CSA C282 Emergency Electrical Power Supply for Buildings.
    - c. CAN/CSA-C802. 2-12 Minimum Efficiency Values for Dry Type Transformers.
  - .4 Illuminating Engineering Society of North America (IESNA).
  - .5 Institute of Electrical and Electronics Engineers (IEEE).

## 8.2 General

- .1 The City of Calgary Facility may be part of a larger master plan and may be required to provide sub feeds to other buildings or future additions. Confirm any future addition requirements with the City of Calgary Project Manager.
- .2 The electrical design shall include capacity as required by the master plan such as:
  - .1 Adequately size utility services.
  - .2 Future breakers, IT ports, etc.
  - .3 Electrical and communication rooms are to be sized to provide space for future equipment and shall be shown in dashed line on the drawings.
  - .4 Do not single source or use proprietary equipment or systems.
  - .5 Consult City of Calgary Corporate Engineering on the appropriate client sub-metering requirements prior to schematic design.

## 8.3 Site Electrical Services

- .1 Consultant to coordinate with the site service utilities and show location and routing of these services to the facility. Site services shall include, but not limited to, electricity, telephony, data and cable TV. The consultant shall also confirm requirement for dedicated City Fibre.
- .2 Avoid crossing any utility service lines unless absolutely deemed necessary. Ensure required clearances are met, co-ordinate with utility provider.
- .3 Consultant to contact electrical service provider to determine service availability, connection costs and date that permanent service can be made available.
- .4 Contractor to provide temporary power and absorb all electrical utilities costs until project is turned over to the Owner.
- .5 Power, telephone and cable television services to, unless impractical, be routed underground from the Utility connection point to the building service equipment.
- .6 Transformers shall be Copper Windings only, no aluminum allowed.
- .7 Provide one (1) spare 103 mm secondary feeder conduit from the exterior pad-mount transformer to the electrical room inside the facility, capped off.
- .8 Provide one (1) spare 103 mm conduit for future communications service provider.
- .9 For new constructions, select service voltage according to the majority of load requirements. 120/208 volt or 347/600 volt, 3 phase, 4 wire are preferred. Use 277/480 volt, 3 phase, and 4 wire only when it is restricted by utility supply or existing service voltage.
- .10 For new constructions and renovations at Waste & Recycling Services' sites where the groundwater table is high, avoid electrical terminations being installed below grade. This is to prevent electrical terminations from being submerged due to seasoned weather events. Consultations with geotechnical engineers or hydrogeologists are encouraged if there is any doubt about the depth of water table in a particular project.

## 8.4 Service Distribution, Sub-Distribution and Panelboards

- .1 Size the main distribution panel and all sub distribution panelboards 25% above the combined current and anticipated future expansion design capacity. Provide adequate spare breakers and spaces in all main and sub distribution panelboards. Allow spare space and/or wall space for future equipment/panelboards in main and sub electrical rooms.
- .2 Use circuit breakers for all main and branch circuit protective devices.
- .3 Preliminary short circuit calculations are required prior to 100% design drawings. Ensure adequate fault duty ratings of all switchgear, panels, MCCs and overcurrent devices based on preliminary short circuit calculation. The contractor/ manufacturer shall complete a Coordination Study that is to be reviewed by the Electrical Consultant and Owner. Upon acceptance of the study, settings shall be programmed for all applicable breakers and a sign and stamped copy of the Study shall be included in the O&M Manual. Electrical Consultant to confirm all breaker settings are coordinated with final Coordination Study Report at substantial completion stage.
- .4 For all City owned and city operated buildings, an arc flash study shall be provided for all new construction, additions, or renovations to existing buildings. For City funded but not City owned facilities, consult the owner for Arc Flash Analysis requirement. Arc flash study to be performed by manufacturer of electrical panelboards. Electrical consultant to include these arc flash requirements into specifications. The scope of the study is as follows:
  - .1 New Buildings: Entire distribution system.
  - .2 Additions and renovations: New distribution systems.
- .5 The maximum arc rating of switchboard on the line side of the main breaker is not to exceed 40 cal/cm<sup>2</sup>. In case non-compliant, proposed measures shall be submitted to the City of Calgary Corporate Engineering and Energy for review and approval.
- .6 The Arc Flash Hazard Analysis to meet CSAZ462 and IEEE 1584. All labels shall be based on recommended or existing overcurrent device settings and will be provided after the results of the analysis have been presented to the owner and after any system changes, upgrades or modifications have been incorporated in the system.
- .7 All arc flash labels shall follow requirement CSA Z462-15 Annex Q - Q.4 Detailed electrical hazard information label.
- .8 Arc Flash Safety training shall be included in the training schedule. Arc flash training shall be provided by the manufacture and shall include:
  - .1 Proper use of the system analysis data.
  - .2 Interpretation of hazard labels.
  - .3 Selection and utilization of personal protective equipment.
  - .4 Safety work practices and procedures.
- .9 A sample of the Arc Flash label shall be provided for review and approval by the engineer and The City of Calgary Corporate Engineering prior to printing all labels.

- .10 Coordination and Arc Flash Studies to be completed in a computer simulated software. The acceptable software to be used is ETAP or SKM Power tools. Soft copies of the project files, including pdf of the report, original ETAP or SKM program files to be provided to the City Corporate Engineering upon completion of the project.
- .11 Provide all floor-mounted equipment with a housekeeping pad (min. 150 mm) except for roll-out style switchgear.
- .12 A dedicated electrical room is required for the main service distribution equipment, metering, etc. The room to be large enough to accommodate electrical equipment and have space to accommodate future needs. The room to be adequately ventilated and located as close as practical to major electrical loads. Provide legible single line diagram which shall be approved by the design Engineer prior to installation in glass frame in main electrical room and generator room if applicable.
- .13 No mechanical or plumbing equipment below and above electrical equipment, to avoid the creation of unnecessary risks. If any fixture runs above an electrical panel, it must be equipped with a drip pan.
- .14 Electrical rooms shall be located above grade.
- .15 Do not locate main service and main distribution equipment in mechanical, storage or janitor rooms except for MCCs in mechanical rooms. Do not locate electrical equipment in or below Janitor rooms, water closet, and washrooms etc.
- .16 Distribution transformers should generally not be located in ceiling spaces.
- .17 Panelboards to be distributed uniformly around the facility sized on the basis of the known and anticipated loads in each area of the facility.
- .18 Branch panelboards are to be located in electrical rooms, but can be located in storage rooms, mechanical rooms upon Owner's approval. Branch panelboards located in mechanical rooms shall serve mechanical equipment within the room only. Where these rooms are not available locate panelboards in corridors and provide with a lockable cover. Master all keys to all panelboards throughout the facility. Do not locate panels behind doors that open in the direction of the panels.
- .19 Coordinate cooling of electrical rooms such as transformers and other heat producing equipment with mechanical consultant.
- .20 Select low temperature rise transformers, using high temperature insulating materials to achieve long life and low losses (e.g., Class 220°C, 150°C temperature rise over a 40°C ambient). Provide three phase transformers with delta-wye grounded connection and accessible voltage taps. All dry type transformers to be K13 rated to mitigate harmonic issues caused by non-linear loads.
- .21 Transformer choking is not allowed.
- .22 Suspended installations are only permitted for transformers less than or equal to 75kVA and where there is a lift accessibility and are not located in ceiling spaces other than open service rooms.
- .23 Provide flexible conduit for final connection to transformer. Provide vibration isolators for transformers located on floors or suspended from upper floors.
- .24 The Engineer shall make recommendations on whether or not provisions for fan cooling shall be provided. Size equipment to full output of transformer (750kVA or above) with fans operating.

- .25 If the project contains many large individual motors (>50HP). The electrical engineer will provide preliminary calculations indicating power factor. If power factor is reduced significantly due to large motor loads, the power factor must be corrected to at least 95%.
- .26 Provide surge protection as follows:
  - .1 Install surge suppression on utility incoming mains.
  - .2 For areas containing a large group of electronically sensitive loads, provide surge protection on distribution equipment serving the area.
  - .3 Specify type 1, type 2 or type 3 for each Surge Protection Devices based on load the SPD protects.
- .27 Provide modular group assembly motor control centres (MCCs) for three phase motor starters.
  - .1 Motor control centres to be complete with:
    - a. Copper bussing.
    - b. 20% spare spaces.
    - c. Individual control transformers in each starter cell.
    - d. Auxiliary contacts for interlocking controls.
  - .2 Do not use fuses for individual motor overcurrent protection.
  - .3 Provide space on back panel in starter for Building Automation current sensors. Sensors to be securely mounted to panel.
  - .4 Coordinate the control requirements with the mechanical engineer and provide all required accessory (e.g., control relays in MCC control terminal section for automated control of motors where required).
  - .5 Coordinate motor sequential starting with building automation controls.
  - .6 The manufacturer of the MCC shall also be the manufacturer of the across-the-line motor starters, across-the-line contactors, solid-state reduced voltage starters, and variable frequency drives. The use of third-party supply and assembly for these components in the MCC is not acceptable.
  - .7 The specifications shall ask contractor to confirm motor full-load amperage ratings and provide those ratings to the MCC manufacturer to achieve proper sizing of the motor branch circuit and overload protection.
- .28 Refer to clause 7.10 for VFD requirements.
- .29 Provide electrical single line diagrams, as part of the Contract Documents, indicating the following:
  - .1 Configuration, type, voltage and current ratings of switchgear, transformers.
  - .2 Panelboards and motor control centres (MCCs).
  - .3 Type, size, amperage ratings of services and feeders.
  - .4 Type, frame size, trip and interrupting rating of all overcurrent protective devices.
  - .5 Available and rated fault current at all switchgear, switchboards, panelboards, transformers secondary, MCCs and overcurrent devices.
  - .6 Connected load at all switchgear, switchboards, panelboards and MCCs.
  - .7 Anticipated demand load at all switchgear, switchboards, panelboards and MCCs.
  - .8 Service and distribution grounding.



- .30 Provide copies of “as-built” single line diagrams as part of the Operating and Maintenance Manuals.
- .31 Provide a copy of “as-built” single line diagram framed and hung in the main electrical room for all new constructions. As-built Single Line Diagram to be updated upon any renovations and additions.
- .32 Panel schedules are to be type written.
- .33 Electrical equipment nameplates shall be secured with drive screws or rivets. Self-adhesive type will not be accepted. Nameplates to be black background with white letter. Nameplate sizes to correspond to the size of the equipment to be identified. Submit each nameplate schedule, size, wording and corresponding size of letters for approval.

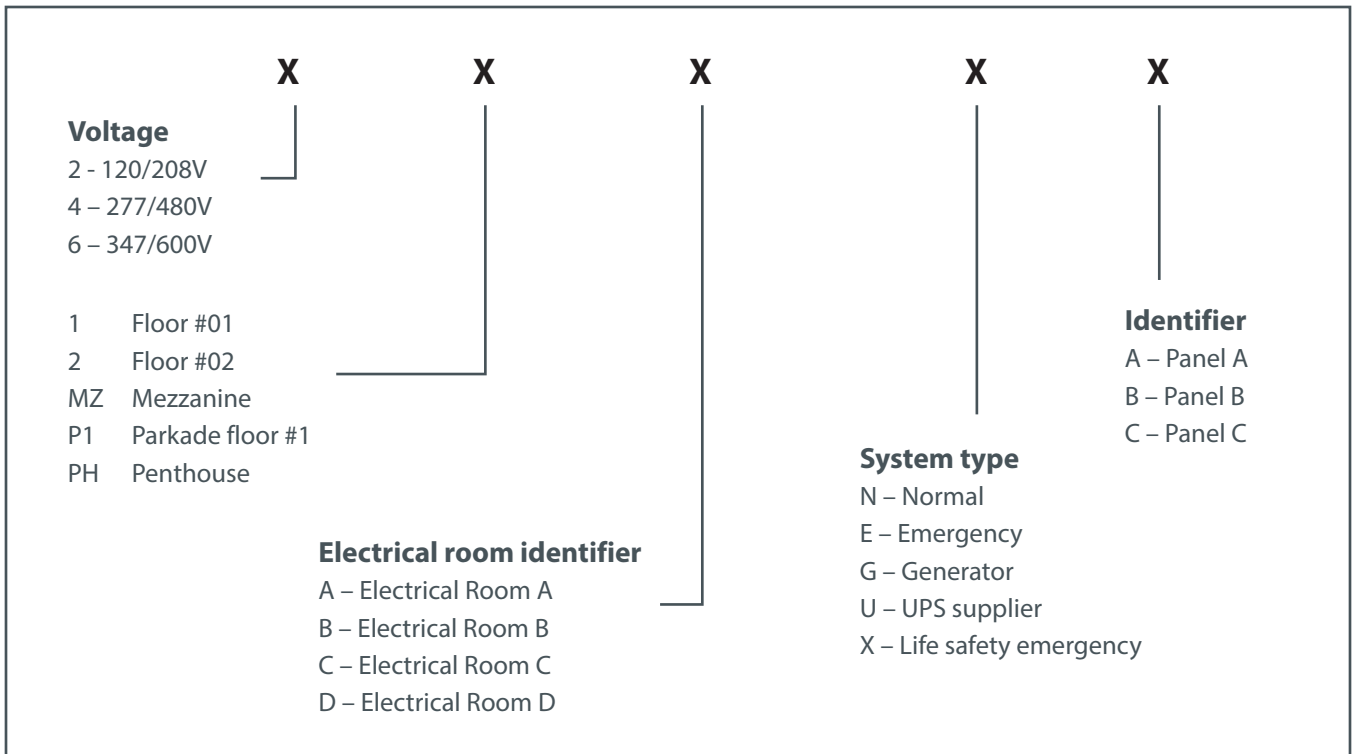
Nameplate sizes:

Size 0	10x50 mm	1 line 3 mm high letters
Size 1a	12x70 mm	1 line 5 mm high letters
Size 1b	12x70 mm	2 line 3 mm high letters
Size 2a	20x90 mm	1 line 8 mm high letters
Size 2b	20x90 mm	2 line 5 mm high letters
Size 3a	25x100 mm	1 line 12 mm high letters
Size 3b	25x100 mm	2 line 6 mm high letters

- .34 For Facility Management owned and/or operated buildings, name electrical panels following panel naming convention illustrated in Figure 8.1. For municipal building and administration building, name electrical panels following Figure 8.2 and 8.3 respectively.

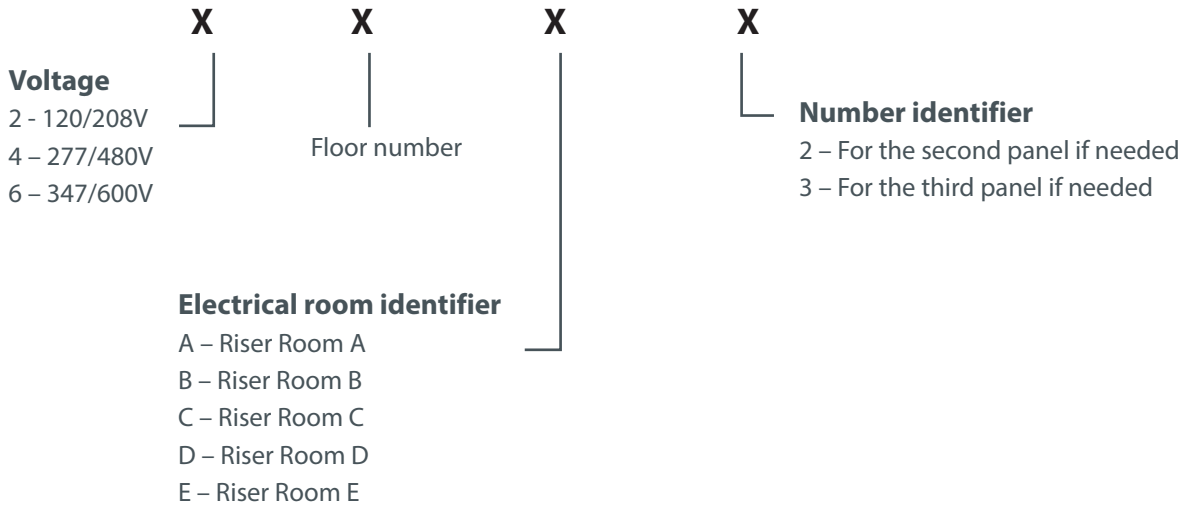
## 8.5 Emergency Power Systems

- .1 Where an emergency generator is provided, ensure compliance with all relevant codes regarding fire separation and fire rated conductors. Make provisions for connection to load bank to facilitate annual full load testing; size only for additional required load, if requested by the Owner.
  - .1 Size generator for peak demand loads plus 25% spare for identified expansion, if applicable.
  - .2 Provide bypass capability at automatic transfer switch for ease of maintenance.
- .2 Consider closed transition (make-before-break) automatic transfer switch to minimize interruption to the operation. The closed transfer control system shall comply with all requirements of the electrical utility, including maximum time that the two sources will remain paralleled together. Open and Closed transition with bypass isolation automatic transfer switches to be considered.

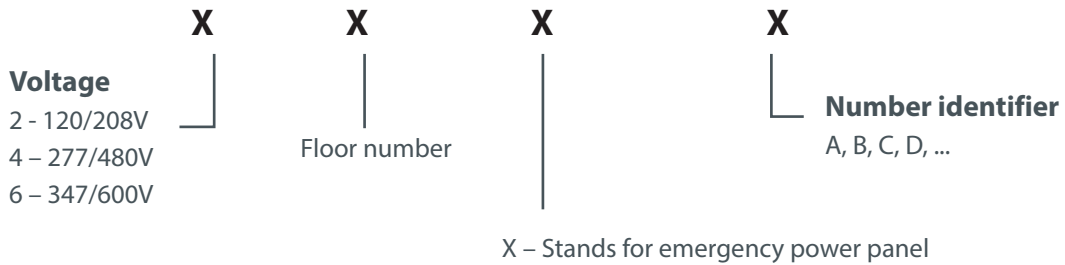


**Figure 8.1 – Electrical Panel Naming Convention**

### Municipal Building Normal Power Panel Naming Instruction



### Municipal Building Emergency Power Panel Naming Instruction



#### Examples

Normal power panel

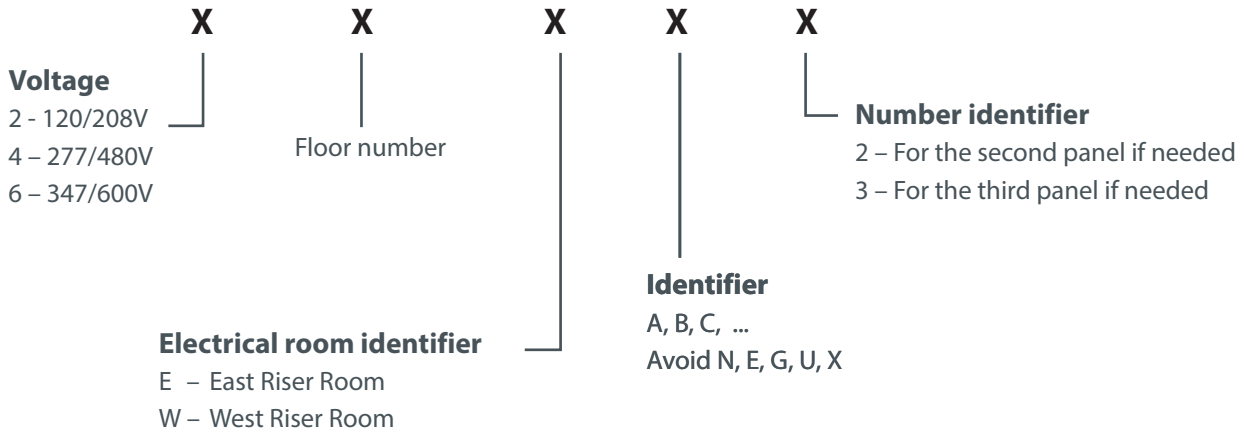
- a) 347/600V panel – 611A (600V, 11th floor, riser room A, panel A) if second 600V panel is needed in riser room A, will name second panel 611A1
- b) 120/208V panel – 211A (208V, 11th floor, riser room A, panel A) if second 208V panel is needed in riser room A, will name second panel 211A1

Emergency power panel

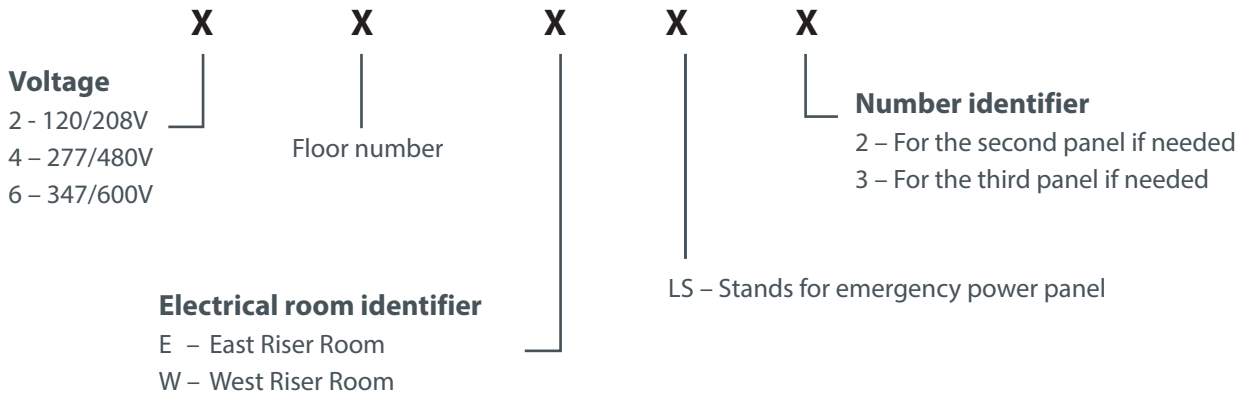
- a) 347/600V panel – 610XA (600V, 10th Floor, emergency power, panel A)
- b) 120/208V panel – 210XA (208V, 10th Floor, emergency power, panel A)

Figure 8.2 – Municipal Building Electrical Panel Naming Convention

### Administration Building Normal Power Panel Naming Instruction



### Administration Building Emergency Power Panel Naming Instruction



#### Examples

Normal power distribution

- a) 277/480V panel – 43EB (480V, 3rd floor, east riser room, panel B)
- b) 120/208V panel – 22EA (208V, 2nd floor, east riser room, panel A)

Emergency power distribution

- a) 120/208V main CDP – CDP-ELS (208V, east life safety)
- b) 120/208V Branch Circuit Panel – 22ELS (208V, 2nd floor, east riser room, life safety panel)
- c) Old 277/480V emergency panels still using existing name (2XDD, 1XA, 1XB, etc.)

**Figure 8.3 – Administration Building Electrical Panel Naming Convention**

## 8.6 Conduit and Wiring

- .1 Provide underground service entrance in duct bank with steel reinforced concrete encased PVC. Provide transition at foundation wall, manholes, etc., with rigid steel conduit. All PVC conduits shall be minimum Schedule 40, DB2 is not allowed.
- .2 All underground installations shall have a warning tape buried at about 300 mm below finished grade.
- .3 Specify all A.C. and D.C. wiring to be installed in conduit or wireway (except where AC90 cables are used). Network, security, and telephone cabling also to be installed in conduit or cable tray where applicable.
- .4 All conduits must be concealed except in service areas where otherwise approved by the owner.
- .5 Provide conduit systems (power, communications, network, etc.) to a point of anticipated future expansion when applicable. Label the purpose of conduit at junction box where conduit terminates.
- .6 For recessed panels, provide three (3) 27 mm conduit stub-outs from all power, communication and protection systems to junction boxes just above ceiling level for future use.
- .7 Record exact routing of underground or in slab conduit runs on record drawings. Provide sufficient details so that the exact route can be determined during renovations and additions. Mark route of in slab conduit runs by using "electrical danger" tape or stained concrete. Do not loop through to downstream outlets.
- .8 Where conduit is used in ceiling plenums, use steel EMT, do not use PVC conduit.
- .9 Provide ventilated cable tray for low tension systems, Class C1, ladder type. Tray to consist of open top cable tray with minimum dimensions of 450 mm wide x 100 mm deep galvanized steel. Cable tray running through fire rated partitions shall be properly sealed with fire stopping.
- .10 For low tension systems, provide conduit for final drops in finished walls from cable tray in ceiling space.
- .11 Size feeders for a maximum 2% voltage drop from main distribution to branch circuit panelboards under rated full loads.
- .12 Minimum conduit size to be 21 mm.



- .13 Panelboard, MCC and distribution board feeders larger than #4/0 AWG may be aluminum alloy. Use copper conductors with RW90 X-Link or THNN insulation. Minimum size of branch circuit wire to be #12 AWG and #14AWG for control wiring. Minimum size of parallel conductors shall be #1/0. Conductor length for parallel conductors to be identical. Ensure manufacturer's recommendations are followed for the installation and terminations of aluminum conductors.
- .14 Circuit Loading:
  - .1 Lighting circuits shall be limited to:
    - a. 1200VA for 15A breaker at 120V and 1700VA for 20A breaker at 120V.
    - b. 2800VA for 15A breaker at 277V and 3700VA for 20A breaker at 277V.
    - c. 3900VA for 15A breaker at 347V and 5300VA for 20A breaker at 347V.
  - .2 Maximum six (6) general convenience receptacles per circuit.
- .15 Maximum four (4) computers receptacles per circuit unless required by their devices subject to movement or water, minimum length to be 460 mm plus 4 times and conduit diameter. Provide a separate ground wire within conduit, bond to motor frames and system ground.

## 8.7 Wiring Devices and Boxes

- .1 Provide a minimum of one, 20 amp (t-slot) housekeeping service outlets in the corridors at approximately 15m intervals.
- .2 Use specification grade receptacles in all locations.
- .3 Identify all receptacles as to panel and circuit number on clear plastic background with black lettering affixed to top of device cover plate.

## 8.8 Lighting

- .1 Minimum Lighting Performance levels to be as per latest IESNA standards.
- .2 Achieve through design compliance per latest National Energy Code of Canada for Buildings requirements.
- .3 All luminaires shall be fixed colour temperature LED. Colour tunable LED luminaires, including dim-to-warm, white tunable, full-colour-tunable, are not recommended for general purpose lighting applications.
- .4 Design to minimize direct and reflected glare.
- .5 The schematic design report should include a lighting design schedule describing each typical area (office, boardrooms, corridors, and etc.), luminaire, lighting source, load (W), lighting power densities (W/m<sup>2</sup>), and design lighting levels (Lx) upon project completion add field measured levels to the report.
  - .1 Minimum LED life shall be 50,000 hours as per LM-80 and tested to LM-79 Standards.
  - .2 LEDs shall conform to UL8750.
  - .3 All drivers to have the capability of dimming function.
  - .4 LED to have operating voltages of 120V, 277V or 347V.

- .5 Interior:
  - a. Minimum CRI  $\geq$  80.
  - b. 3500K - 4000K.
  - c. All LED luminaires shall be the same colour temperature throughout the facility for consistency. For renovation and addition projects, lighting designer/consultant shall use LED luminaires with colour temperature that matches existing LED luminaires within the same facility (unless noted otherwise).
  - d. Colour temperature of any new LED luminaires installed at Municipal Building shall be 3500K.
- .6 Exterior:
  - a. IP65 or better.
  - b. Minimum CRI  $\geq$  70.
  - c. 4000K.
  - d. Surge protection capability.
- .7 Warranty:
  - a. Minimum of 5 years of LEDs and driver.
  - b. Minimum of 10 years on housing and finish.
- .6 Use day lighting wherever feasible and provide detailed information in design development report.
- .7 Provide an outline of how day lighting is to be integrated into the facility, how automatic control is achieved and how glare is controlled.
- .8 Provide occupancy sensor for lighting control in individual rooms where lighting is not required on a continuous basis including offices, storage rooms, service rooms, washrooms, training rooms, fitness rooms, boardrooms and meeting rooms. Use motion sensor controlled lighting for open areas where feasible.
- .9 Install daylight sensors and occupancy sensors with 1000 mm of slack wires to permit subsequent relocation without the need for rewiring (drop ceiling T-bar only).
- .10 In rooms where audio/visual presentations are likely, provide a second level of lighting through switching a small number of luminaires separately from the main lighting.
- .11 All exterior lighting shall be controlled through any one or combination of the following; photocell, astronomical time clock or energy management control system/ controller.
- .12 Do not use breaker switching.

## 8.9 Emergency and Exit Lights

- .1 Make standby battery provisions for emergency lights and exit signs, where an emergency generator is not provided as part of the base building scope.
- .2 Exit Signs are to be LED.
- .3 Remote heads are to be LED, in white finish.
- .4 Battery operated emergency lighting units are to be complete with long-life sealed lead acid batteries, 10 year life expectancy, fully automatic charger, built-in test switch, charge indicator, units to be hard wired to outlet box (Do not use receptacle/cord set connection). Units are to be on the same circuit as the serving area lights (if there is a generator emergency lights then Battery Units to be on same circuit as emergency lights).
- .5 When an emergency generator is used as emergency power, provide a dedicated battery powered emergency lighting in the following spaces:
  - .1 Generator Room, if applicable.
  - .2 Mechanical, Electrical and Communication Rooms.

## 8.10 Fire Alarm System

- .1 Select system vendors with local support.
- .2 Provide fire alarm system as a stand-alone system, independent of building control or security systems.
- .3 Locate the main fire alarm panel at fire department main entrance to reduce cost for annunciator. If an annunciator is required, display height for installation should be 1.6m to center of display.
- .4 Pullstations shall be on latch side of doors only.
- .5 Splices (T-Taps) are not permitted.
- .6 Drawings:
  - .1 Separate fire alarm from other electrical drawings whenever possible.
  - .2 Show interference elements from other systems.
  - .3 Show zone boundaries and provide a zone schedule.
  - .4 Provide a riser schematic for network communications.
  - .5 Provide a sequence of operations chart for complicated signalling or automated smoke management.

## 8.11 Security System

- .1 Coordinate with Corporate Security for City of Calgary corporate security requirement.

## 8.12 Public Address System

- .1 Provide a public address system capable of communicating throughout the facility for emergency and other purposes using telephones and the public address speaker system, if applicable.
- .2 Coordinate with Corporate Security for City of Calgary corporate security requirement.

## 8.13 Telephone System

- .1 Coordinate Structured Wiring requirements with the City of Calgary IT department and to comply with IT Voice, Data and Wireless Infrastructure Standards.

## 8.14 Computer Network System

- .1 Coordinate Structured Wiring requirements with the City of Calgary IT department and to comply with IT Voice, Data and Wireless Infrastructure Standards.

## 8.15 In Building Cellular Communication Services

- .1 Coordinate in building cellular coverage requirements, which is to connect the cellular service from one or multiple national telecommunications company, with the City of Calgary IT department and to comply with IT Cellular Coverage, Voice, Data and Wireless Infrastructure Standards.

## 8.16 Cable Television System

- .1 Coordinate with Occupying Business Unit for their requirements.

## 8.17 Lightning Protection System

- .1 Confirm if a lightning protection system is required by completing a risk assessment as described in CAN/CSA-B72. Coordinate with Lightning Consultants.

## 8.18 Electrical Start-up and Testing

- .1 Include a complete list and test report forms for all tests required in the specification. Identify which test needs the consultant engineer to witness.
- .2 Basic electrical start-up and testing shall include, but not limited to:
  - .1 Test and check all portions of the electrical systems for satisfactory operation.
  - .2 Before energizing any portion of the electrical systems:
    - a. Perform megger tests on all feeder conductors.
    - b. Torque all bus connections to manufacturer's requirements and seal with red lacquer.
    - c. Measure ground resistance of ground grids and wiring devices with earth test megger to verify compliance with CSA C22.2 No. 0.4-M1982 and Canadian Electrical Code, and submit test results to Consultant.
    - d. After energizing as many loads as possible, test load balance on all feeders at distribution centres, motor control centres and panelboards. If load unbalance exceeds 15%, reconnect circuits to balance loads and revise panelboard directories and wiring identification accordingly.
    - e. Test and calibrate all protective devices on site prior to energizing to ensure proper operation as determined by final coordination studies.
    - f. Prior to starting motors, confirm motor nameplate data with motor starter heater overloads, verify rotation, ensure disconnect switches are installed and confirm labelling of motors, disconnects and starters.
    - g. Functional test of all lighting switches, luminaires, dimmers and lighting control equipment such as photocells and time clock settings.
    - h. Check operation of all battery operated emergency lighting units, exit lights and connection of exit lights to emergency lighting units as specified.
    - i. Test operation of UPS.
    - j. Factory and field test standby power generation systems.
    - k. Complete fire alarm verification as per current addition of CAN/ULC-S527 Verification of Fire Alarm System.
    - l. Test signal strength at each cable television outlet and provide verification that signal levels meet specified requirements.
- .3 All tests to be recorded on the test report forms and submitted to the consultant.

## 8.19 Acoustics and Vibration

- .1 Refer to Section 9 - Acoustics and Vibration.





## Section 9 – Acoustics and Vibration

9.1	Codes and Standards .....	71
9.2	Architectural .....	71
9.3	Structural .....	71
9.4	Mechanical .....	72
9.5	Electrical .....	73

## 9.1 Codes and Standards

- .1 In addition to the documents listed in Section 1.4, new design, additions, upgrades and repairs to conform to or exceed the latest edition of the following codes and standards generally, plus those specifically referenced in following clauses:
  - .1 ASHRAE; Applications Handbook; Sound and Vibration Control Chapter.
  - .2 CISC Handbook of Steel Construction – Appendix G, Guide for Floor Vibrations.

## 9.2 Architectural

- .1 Consult with the client business unit or civic partner on rooms where speech privacy, sound isolation, background noise, or reverberation noise is critical.
- .2 Develop a floor plan so that noise-sensitive spaces are not next to high noise generating areas. Consider both vertical and horizontal adjacencies.
- .3 Floor Construction: evaluate the need for a floating concrete floor to isolate loud equipment in mechanical areas. The engagement of an acoustic consultant may be required to make an evaluation on the level of mechanical noise, and provide a design that attenuates the developed noise.
- .4 Wall Construction: for rooms with acoustic considerations (this may include offices where sensitive conversations are to be held), walls should run to underside of structure or include a drywall ceiling. Joints/penetrations shall be sealed relative to the acoustic consideration required. For highly critical acoustic transmission requirements the use of an acoustic consultant for detailing may be required.
- .5 Doors: in walls where acoustic considerations are included, doors shall also be considered for their STC levels.
- .6 Consideration of actual STC ratings (aSTC) should be used where possible instead of design/theoretical STC ratings.

## 9.3 Structural

- .1 Mechanical room floors to be minimum 130 mm thick concrete, to minimize structural vibration problems.
- .2 Provide 100 mm thick concrete housekeeping pad for major mechanical equipment.
- .3 Design structural steel framed floors to prevent transient footstep-induced vibration from exceeding the annoyance threshold. Refer to CISC Handbook for Steel Construction – Appendix G Guide for Floor Vibration.
- .4 Ensure rooftop mechanical equipment is located on the roof structure so as to avoid resonance problems. Coordinate with architect and mechanical consultant to mitigate vibration and noise due to rooftop mechanical equipment.

## 9.4 Mechanical

.1 Design mechanical systems to provide background Noise Criterion (NC) noise levels as follows:

.1	Offices	30 – 35
.2	Meeting Rooms	30 – 35
.3	Conference Rooms	25 – 30
.4	Corridors and Lobby Areas	35 – 40
.5	Warehouse and Storage Areas	40 – 45
.6	Computer Rooms	40 – 45
.7	Maintenance / Shop Areas	45 – 50
.8	Fitness Areas	40 (maximum)
.9	Pool Areas	35 (maximum)
.10	Outdoor Areas	45 (maximum)

For areas not listed refer 2015 ASHRAE Handbook, HVAC Applications, Chapter 48, and Table 1.

.2 Confirm with client business unit or civic partner if there are any other acoustically critical areas within the project scope.

.3 Vibration Isolation:

- .1 Use the latest ASHRAE Application Handbook as a guide for selecting vibration isolation of mechanical equipment.
- .2 Provide vibration isolators for all pipe hangers.
- .3 Utilize flexible connections on pump inlet and outlets.

.4 Ducts, Terminal Units, Air Handling equipment:

- .1 Avoid placing rooftop equipment over noise-sensitive areas. Provide details describing acoustic treatment, duct configuration and roof penetration seals for any rooftop installations.
- .2 Locate balancing damper as close to branch takeoff from main as possible.
- .3 Use flexible connections between fans, plenums, and all related ductwork.
- .4 Exhaust fans serving meeting and conference rooms should be located in ceiling spaces above adjacent less critical areas such as corridors.
- .5 Select grilles and diffusers such that the combined noise from all devices in a room meets the design criteria.
- .6 Ensure placement of return air grilles minimizes cross-talk between adjacent rooms.
- .7 Acoustically line return air ductwork from AHUs and RTUs. Acoustically line the first 3m of supply air ductwork from AHUs, RTUs, and MUAs at a minimum. Consider use of factory-built silencers on supply and return connections from units where acoustics are critical.
- .8 Utilize low-velocity acoustically lined transfer ducts constructed so as to eliminate straight line of sight through the duct.
- .9 Provide minimum 900 mm of acoustically lined ductwork or factory attenuators downstream of all VAV terminal units. All supply air takeoffs to be installed downstream of lined ductwork / attenuator.

.5 Plumbing Noise:

- .1 Ensure sleeves are provided for piping that penetrates walls. Seal space between pipe and sleeve with caulking.
- .2 Install water hammer arrestors at all quick-acting solenoid valves.

## 9.5 Electrical

.1 Transformers:

- .1 Avoid locating transformers within or above/below noise-sensitive areas.
- .2 Provide vibration isolators for transformers located near occupied spaces.
- .3 Provide flexible conduit for connections to the transformer.





# Section 10 – Environmental/Hazardous Materials

10.1 Environmental/Hazardous Materials.....75



## 10.1 Environmental/Hazardous Materials

- .1 This section applies to existing buildings.
- .2 Where a hazardous materials audit is not available or does not exist, contact the client business unit or civic partner prior to starting detail design, any destructive investigation or any construction activities. Reach out to the client business unit or civic partner safety representative to discuss whether an audit is warranted.
- .3 Where any existing hazardous materials are not normally accessible by staff or public, and where they are undamaged and not friable, they may be able to be recorded and left in place. If they are accessible, damaged or friable, the client business unit or civic partner may decide to encapsulate them. Where they will be disturbed during an upgrade or renovation, or where they may pose a hazard to staff or trades performing normal operating maintenance, those materials are to be removed in accordance with regulations and recognized safe practices: coordinate with the client business unit or civic partner and their respective safety representative as to whether to include removal in project scope.



**Questions and comments on these guidelines are welcome and should be referred to:**

Acting Manager, Corporate Engineering and Energy	Ron Raymond	ron.raymond@calgary.ca
Leader, Engineering Services	Marco Mazzolani	marco.mazzolani@calgary.ca
Sustainability	Arsheel Hirji	arsheel.hirji@calgary.ca
Civil, Structural, and Building Envelope	Atul Paranjape	atul.paranjape@calgary.ca
Mechanical	Erin Dewar	erin.dewar@calgary.ca
Electrical	Cathy Wu	cathy.wu@calgary.ca
Energy Management	Ron Raymond	ron.raymond@calgary.ca
Architecture	Shawna Cochrane	shawna.cochrane@calgary.ca
General inquiries:	Marco Mazzolani	marco.mazzolani@calgary.ca